



# TECHNICAL CATALOGUE

## **ALUMINIUM**





|                       |    |
|-----------------------|----|
| DA-65 EF              | 4  |
| DA-65 EFUS            | 20 |
| DA-70C                | 30 |
| DA-77                 | 32 |
| DA-90 THERMO          | 53 |
| DA-77 HST             | 64 |
| DA-40 ST              | 69 |
| DA-51 ST              | 72 |
| DA-51 HST             | 80 |
| DA-77N PANEL DOORS    | 91 |
| DA-77 FD FOLDING DOOR | 93 |



**DA-65 EF**

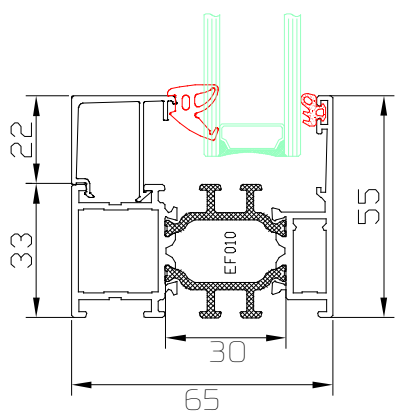

DA-65 EF  
Fixed window  
Frame: EF010

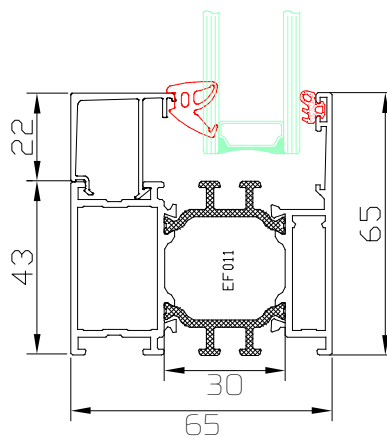

DA-65 EF  
Fixed window  
Frame: EF011 - for roller shutters

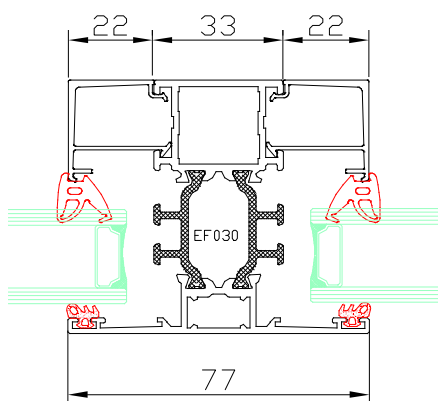

DA-65 EF  
Crossbar - Fixed window  
Mullion: EF030

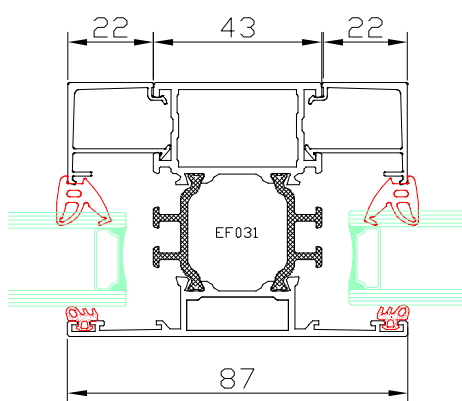

DA-65 EF  
Crossbar - Fixed window  
Mullion: EF031

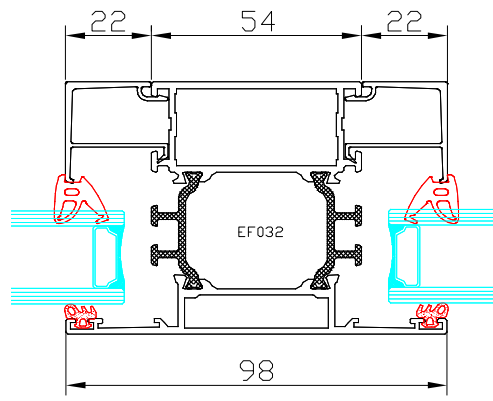

DA-65 EF  
Crossbar - Fixed window  
Mullion: EF032

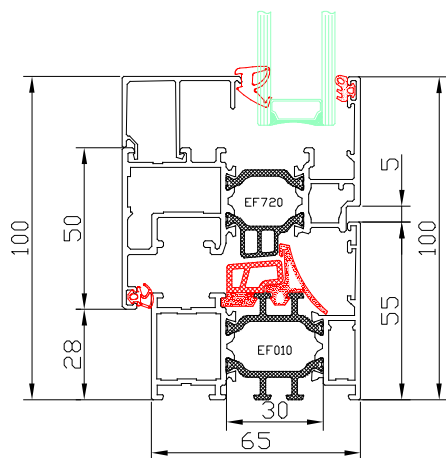

DA-65 EF  
Tilt-and-turn window, Turn window  
and Tilt window  
Frame: EF010  
Sash: EF720

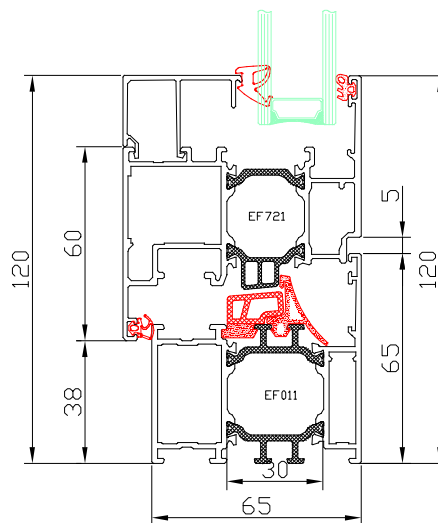

DA-65 EF  
Tilt-and-turn window, Turn window  
and Tilt window  
Wide frame: EF011  
Wide sash: EF721

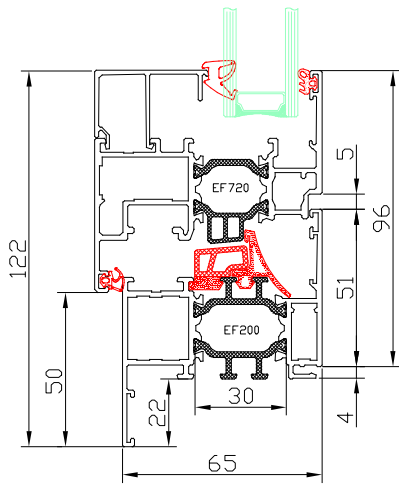

|   |
|---|
| DA-65 EF  |
| Tilt-and-turn window, Turn window and Tilt window |
| Frame: EF200                                      |
| Sash: EF720                                       |

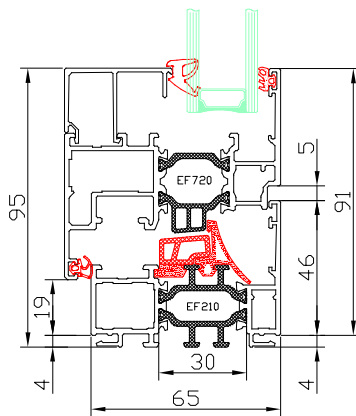

|   |
|---|
| DA-65 EF  |
| Tilt-and-turn window, Turn window and Tilt window |
| Frame: EF210                                      |
| Sash: EF720                                       |

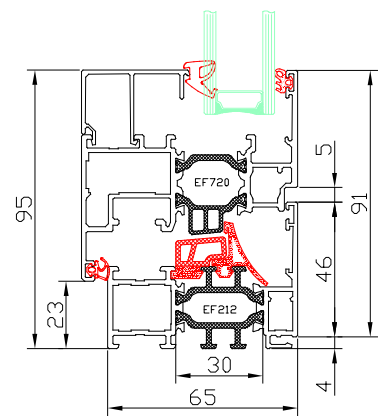

|   |
|---|
| DA-65 EF  |
| Tilt-and-turn window, Turn window and Tilt window |
| Frame: EF212                                      |
| Sash: EF720                                       |

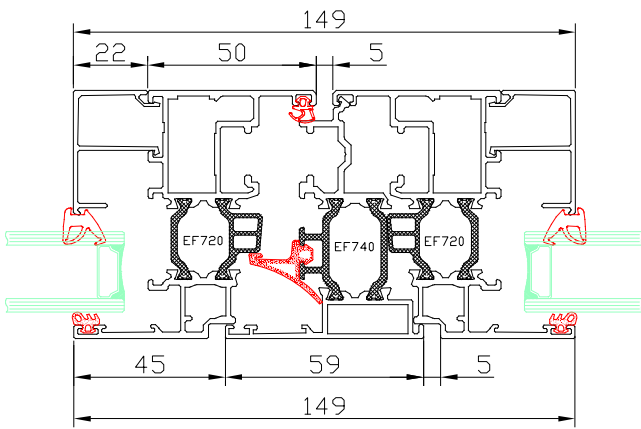

|                 |
|-----------------|
| DA-65 EF        |
| Movable mullion |
| Mullion: EF740  |
| Sash: EF720     |

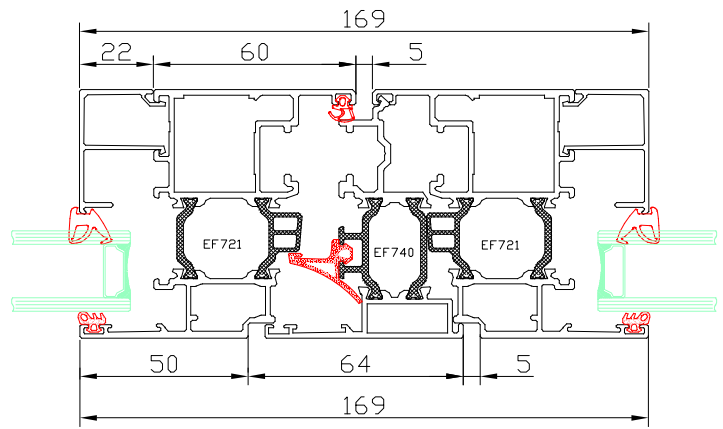

|                  |
|------------------|
| DA-65 EF         |
| Movable mullion  |
| Mullion: EF740   |
| Wide sash: EF721 |

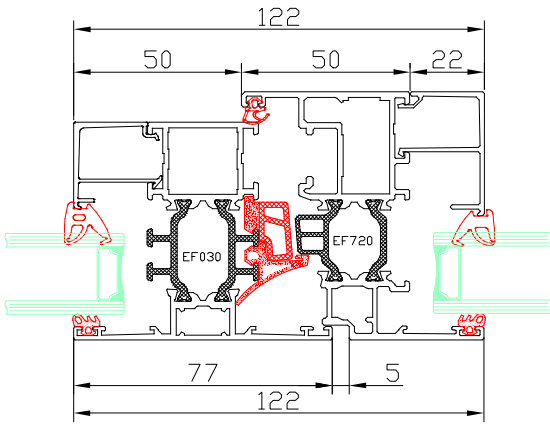

|   |
|---|
| DA-65 EF  |
| Mullion for Tilt-and-turn window and fixed window |
| Mullion: EF030                                    |
| Sash: EF720                                       |

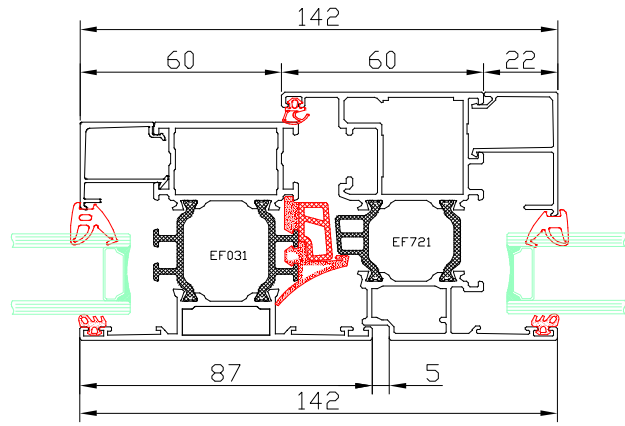

|   |
|---|
| DA-65 EF  |
| Mullion for Tilt-and-turn window and fixed window |
| Mullion: EF031                                    |
| Wide sash: EF721                                  |

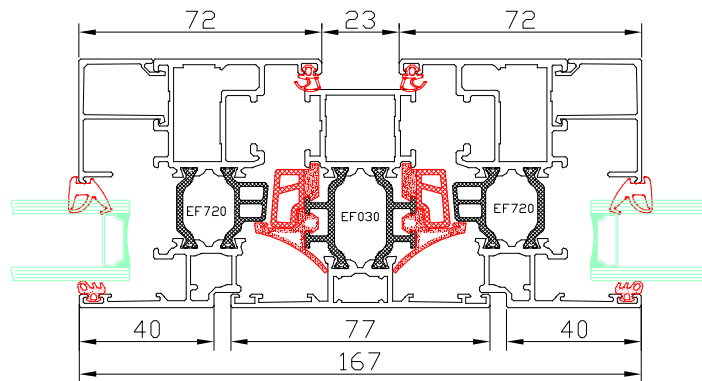

|                                    |
|------------------------------------|
| DA-65 EF                           |
| 2 sash window with a fixed mullion |
| Mullion: EF030                     |
| Sash: EF720                        |

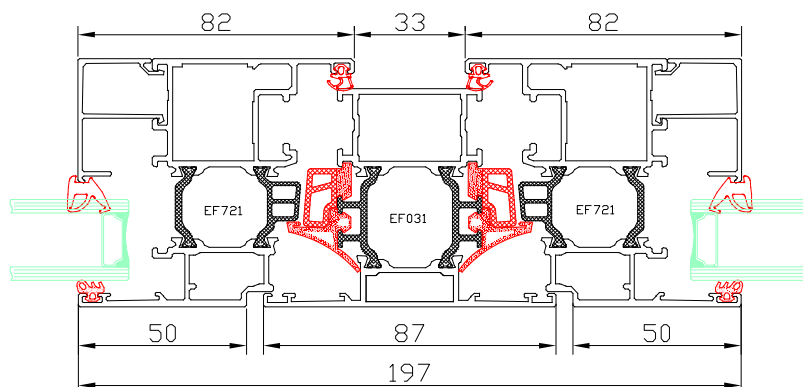

|                                    |
|------------------------------------|
| DA-65 EF                           |
| 2 sash window with a fixed mullion |
| Mullion: EF031                     |
| Wide sash: EF721                   |

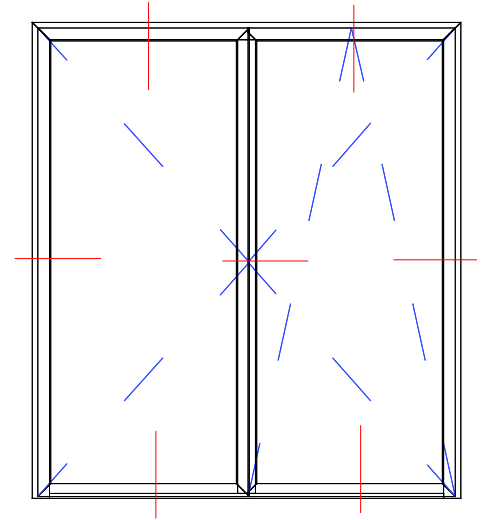
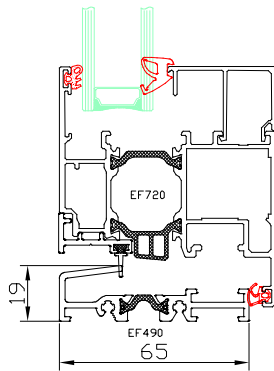
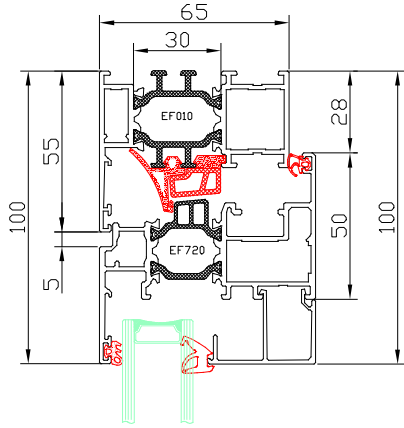

|                           |
|---------------------------|
| DA-65 EF                  |
| 1 or 2-sash balcony doors |
| Frame: EF010              |
| Sash: EF720               |
| Mullion: EF740            |
| Threshold: EF490          |

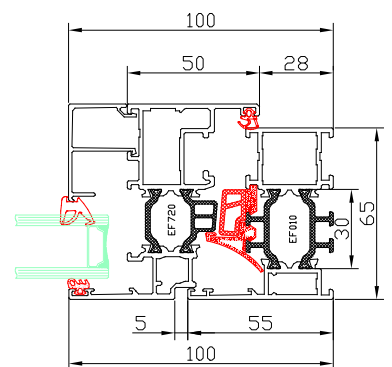
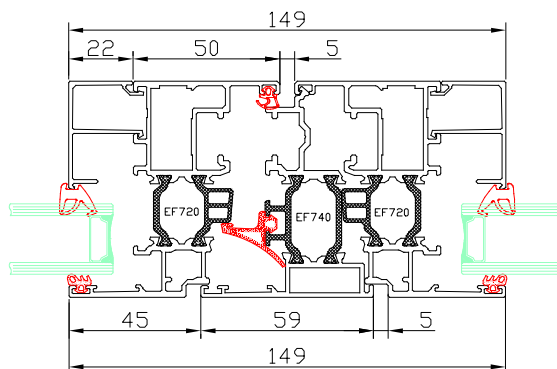
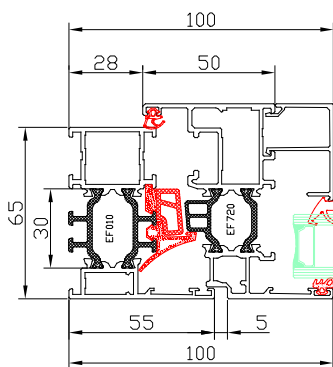

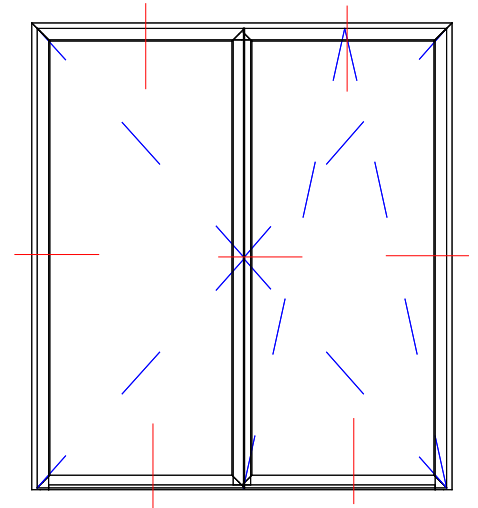
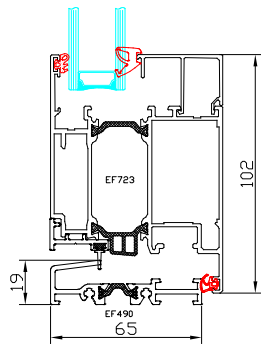
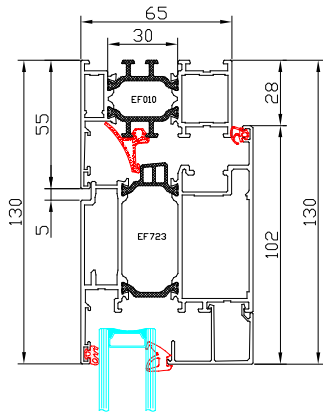

|  |
|--|
| DA-65 EF   |
| 1 or 2-sash balcony doors with a handle and two-sided lock |
| Frame: EF010   |
| Sash: EF723  |
| Threshold: EF490   |

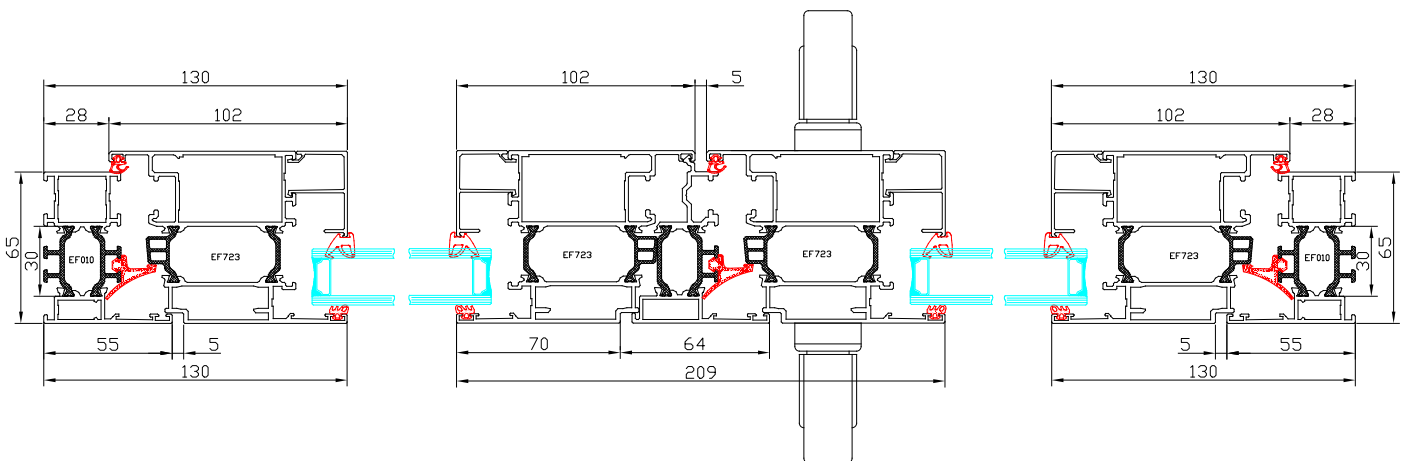

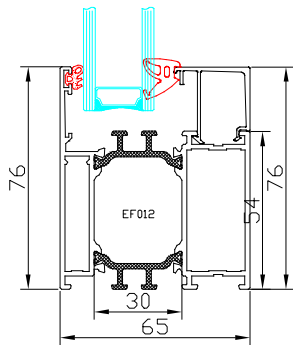
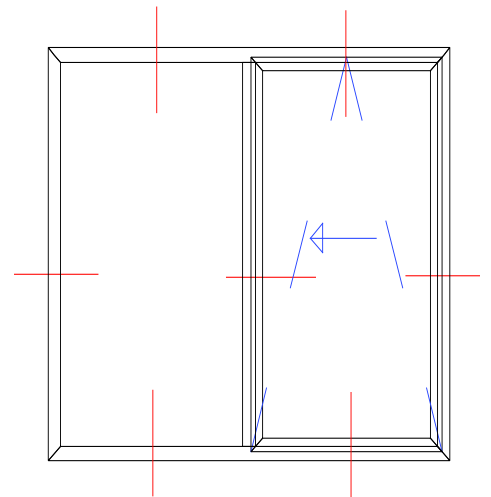
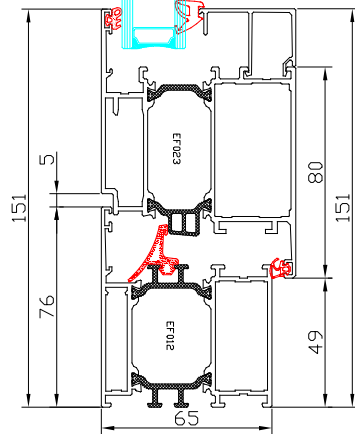
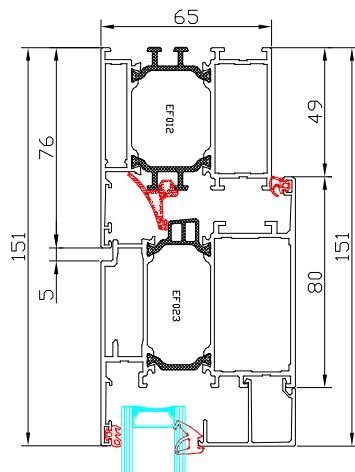
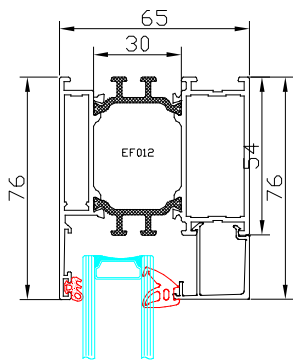

|                        |
|------------------------|
| DA-65 EF               |
| Tilt-sliding HKS doors |
| Frame: EF012           |
| Mullion: EF030         |
| Sash: EF020            |

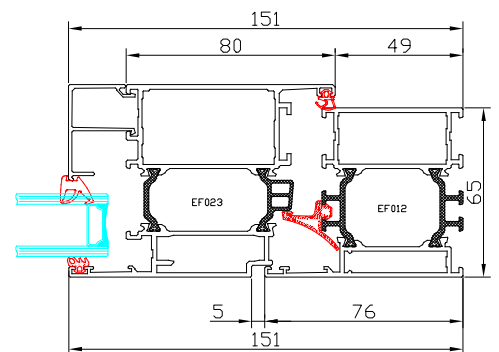
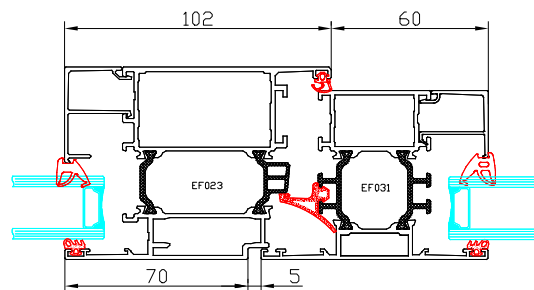
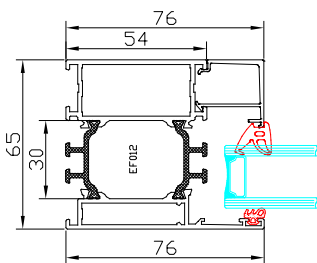



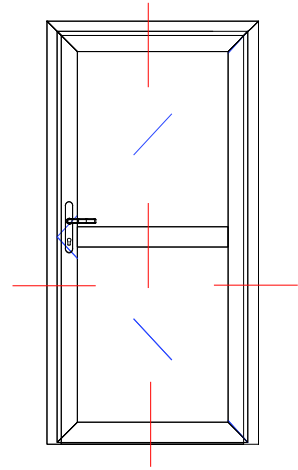
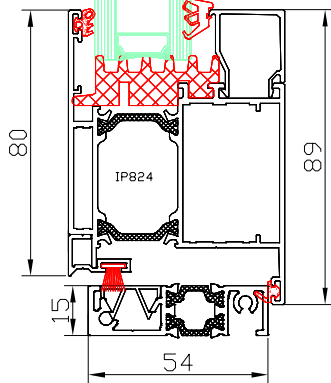
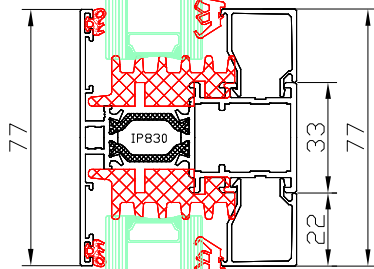
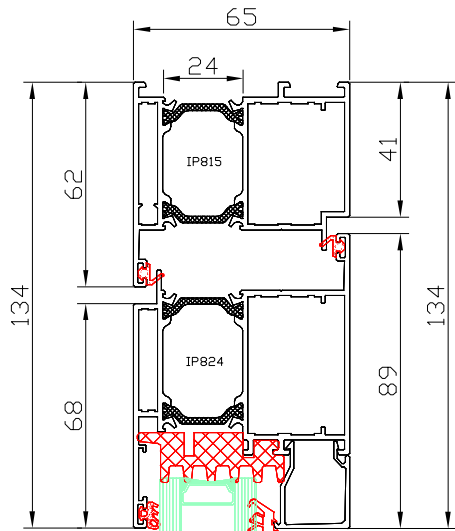

|                                  |
|----------------------------------|
| DA-65                            |
| Single-sash door opening inwards |
| Frame: IP815                     |
| Crossbar: IP830                  |
| Threshold: 15 mm                 |
| Sash: IP824                      |

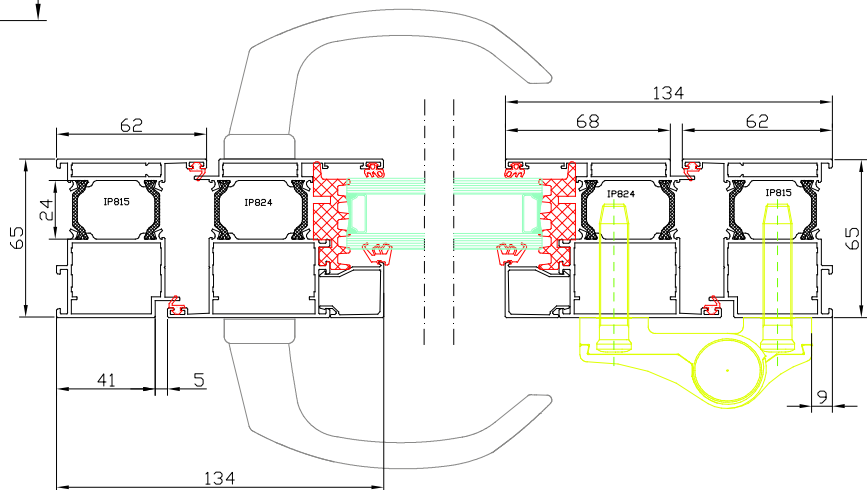

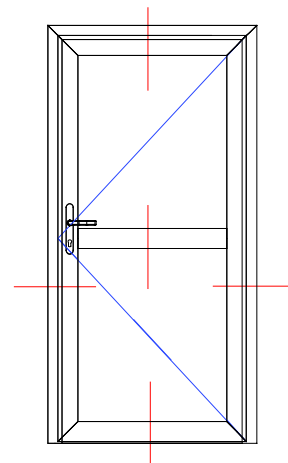
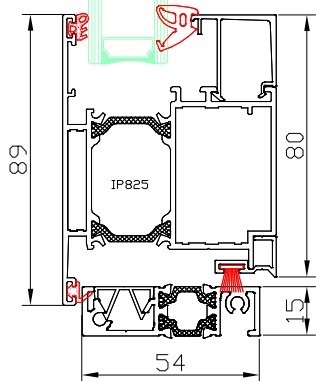
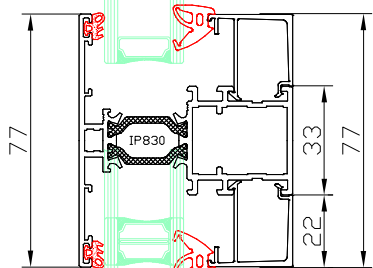
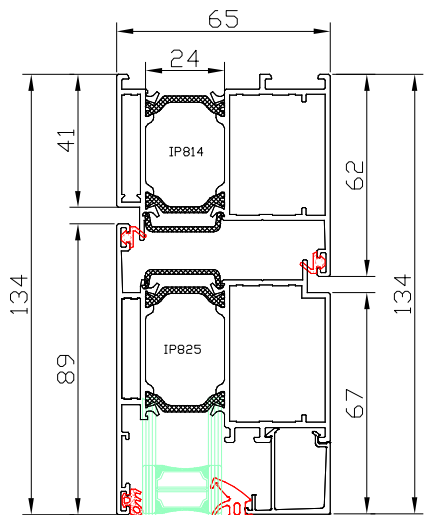

|                                   |
|-----------------------------------|
| DA-65                             |
| Single-sash door opening outwards |
| Frame: IP814                      |
| Crossbar: IP830                   |
| Threshold: 15 mm                  |
| Sash: IP825                       |

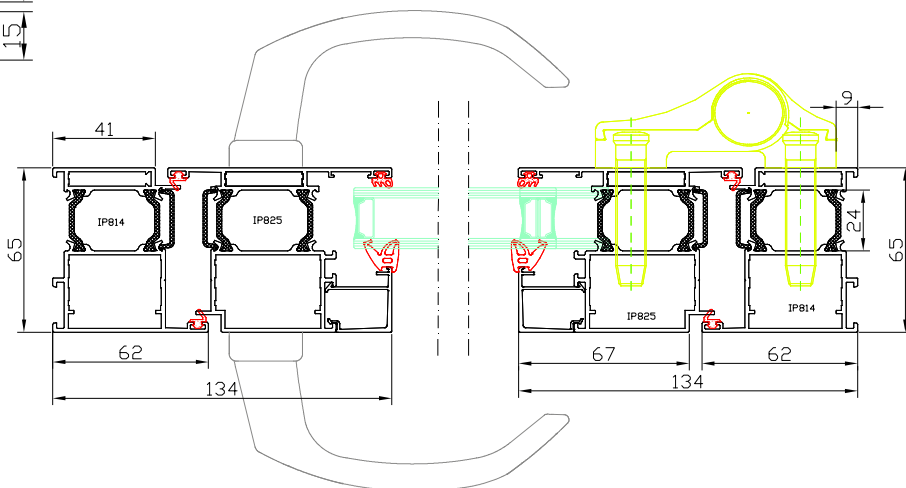

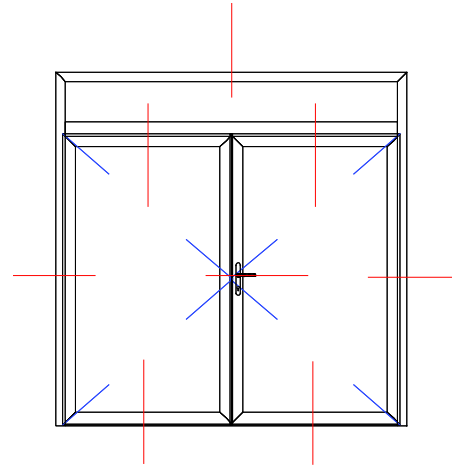
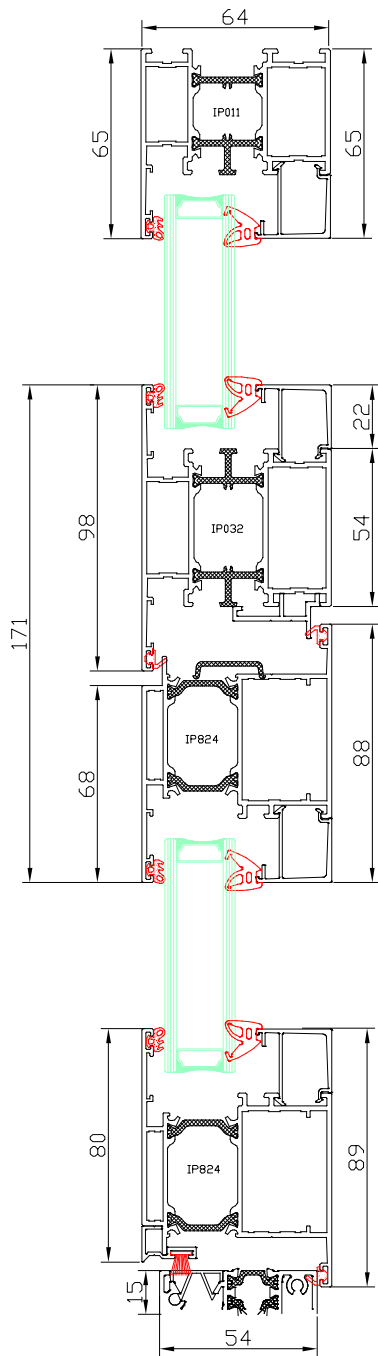

|                             |
|-----------------------------|
| DA-65                       |
| 2-sash door opening inwards |
| Frame: IP011                |
| Mullion: IP032              |
| Threshold: 15 mm            |
| Sash: IP824 i IP824         |

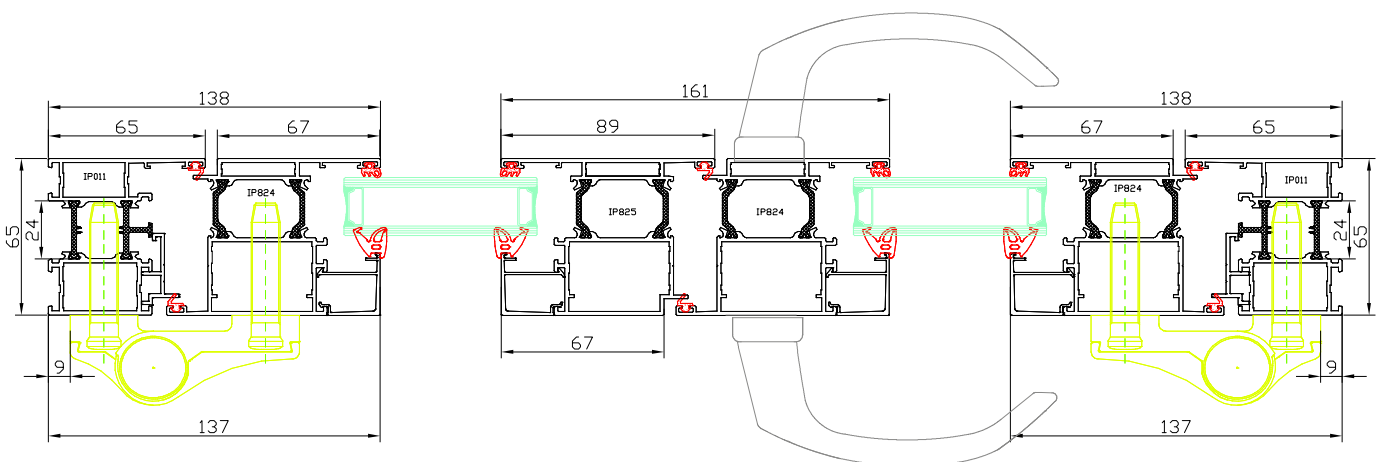

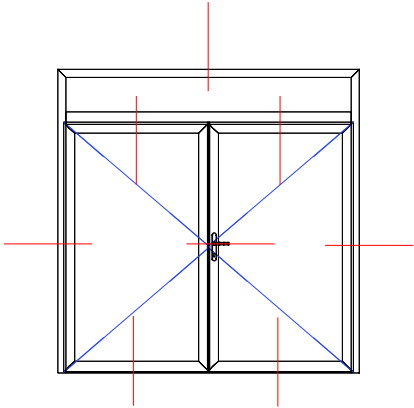
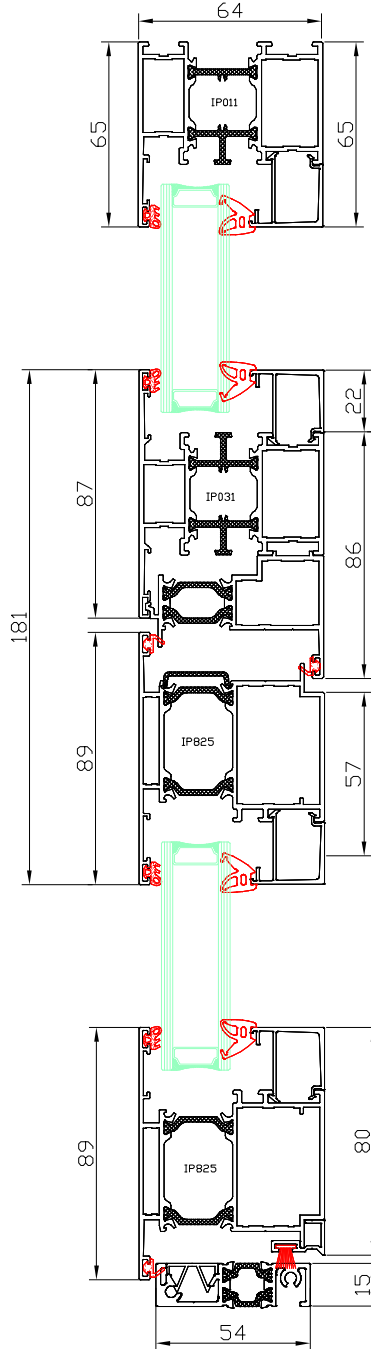

|                              |
|------------------------------|
| DA-65                        |
| 2-sash door opening outwards |
| Frame: IP011                 |
| Mullion: IP031               |
| Threshold: 15 mm             |
| Sash: EF824   EF825          |

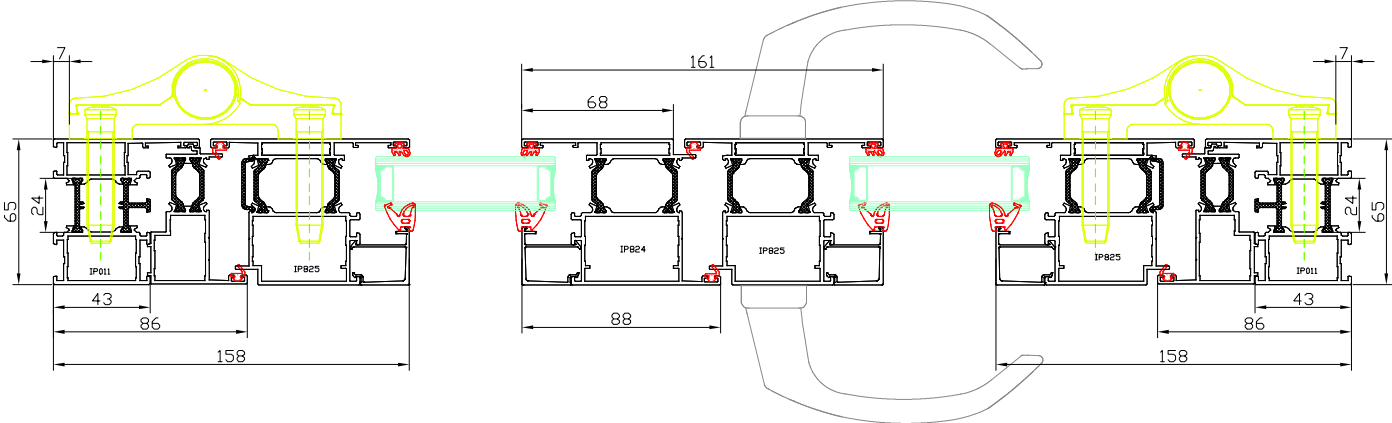

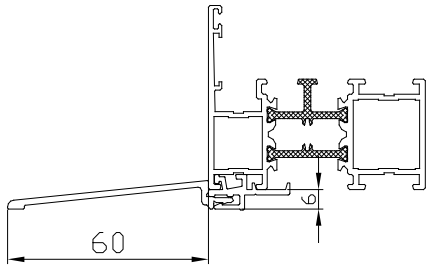

DA-65 EF  
Sill profile (window sill) UN320 + UN119

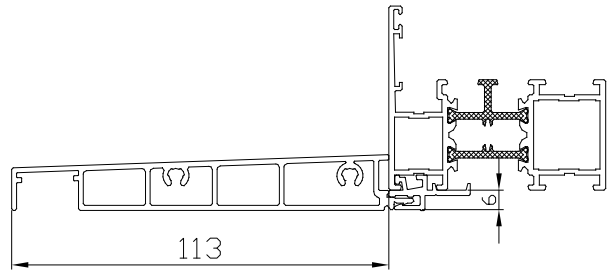

DA-65 EF  
Sill profile (window sill) EF2000 + UN119

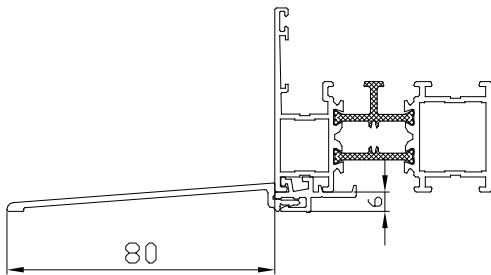

DA-65 EF  
Sill profile (window sill) UN321 + UN119

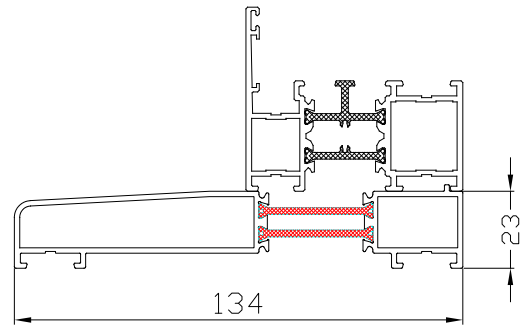

DA-65 EF  
Sill profile (window sill) IN357

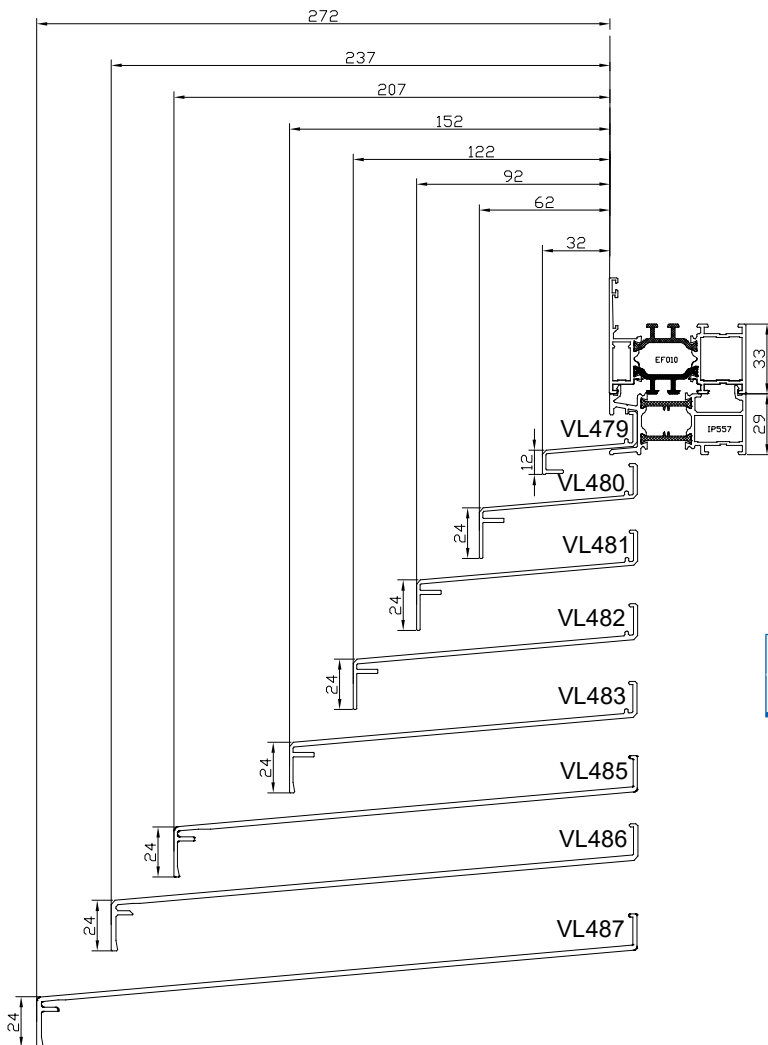

DA-65 EF  
Sill profile (window sill)

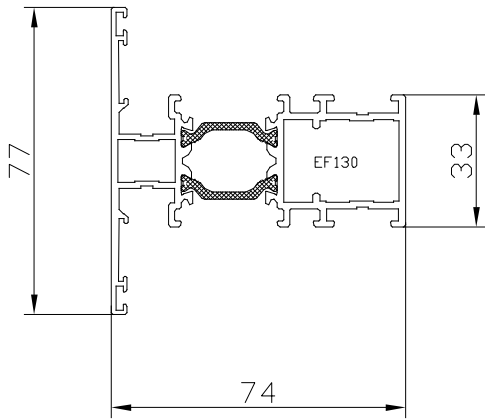

DA-65 EF  
Crossbar in the sash

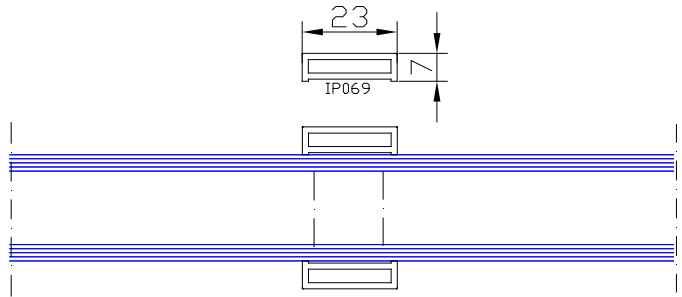

DA-65 EF  
Glued-on muntin bars + DUPLEX:  
inter-pane muntin bars

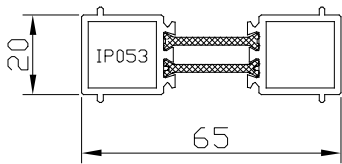

DA-65 EF  
Connector IP053

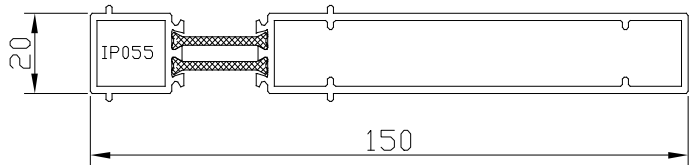

DA-65 EF  
Connector IP055

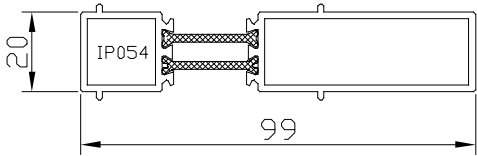

DA-65 EF  
Connector IP054

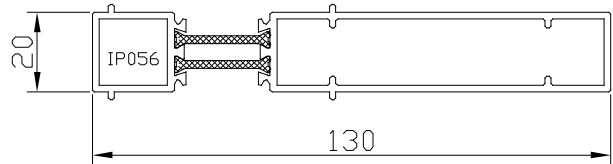

DA-65 EF  
Connector IP056

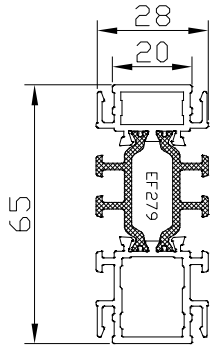

DA-65 EF  
Expansion Joint EF279

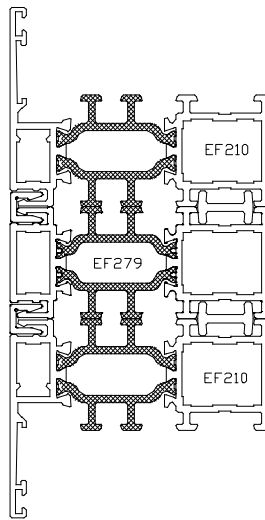

DA-65 EF  
Expansion Joints EF279 (example)

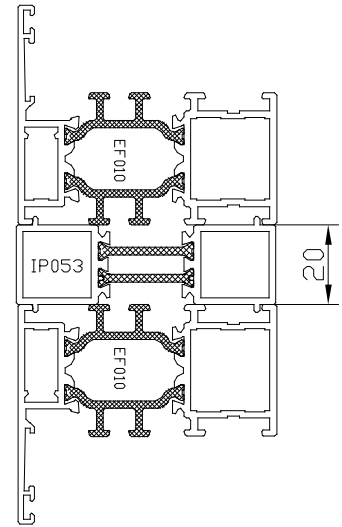

DA-65 EF  
Connectors IP053 (example)

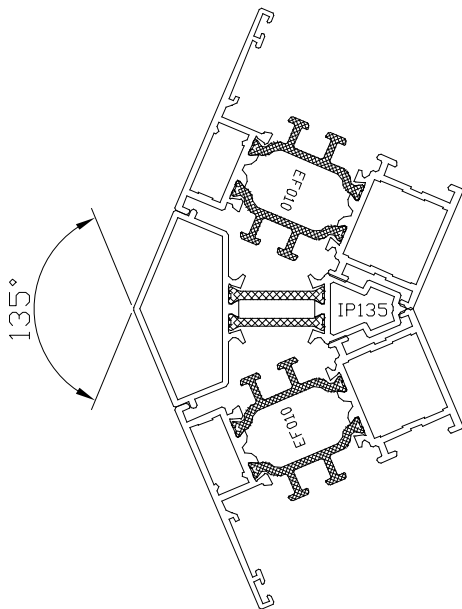

DA-65 EF  
Corner joint IP135

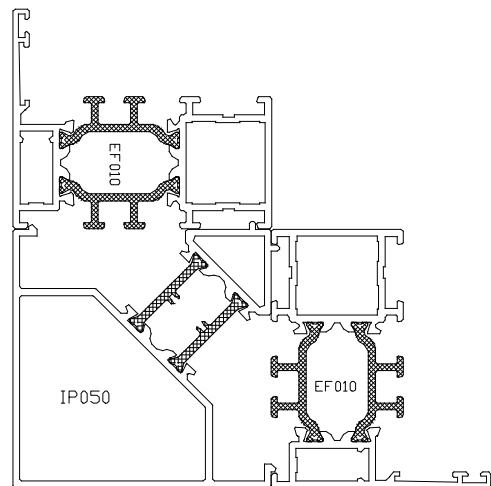

DA-65 EF  
Corner joint IP050

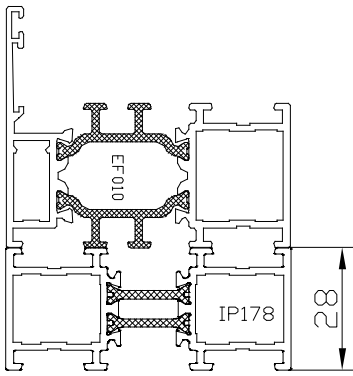

DA-65 EF  
Expander IP178 (example)

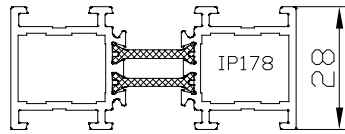

DA-65 EF  
Expander IP178

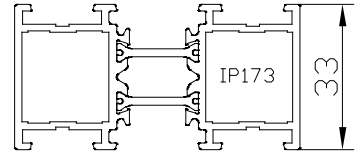

DA-65 EF  
Expander IP173

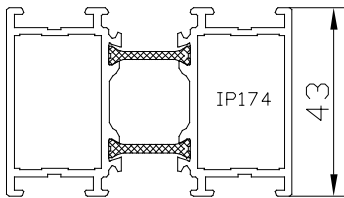

DA-65 EF  
Expander IP174

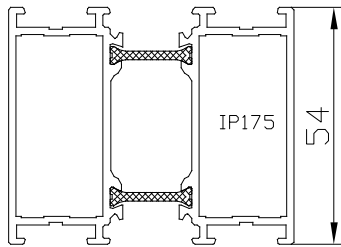

DA-65 EF  
Expander IP175

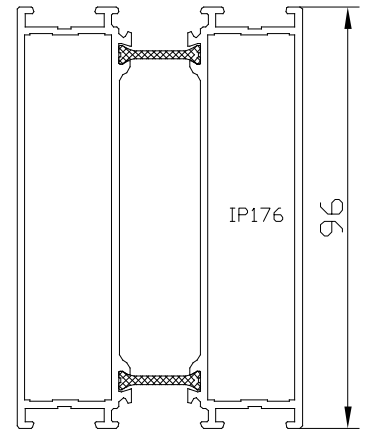

DA-65 EF  
Expander IP176

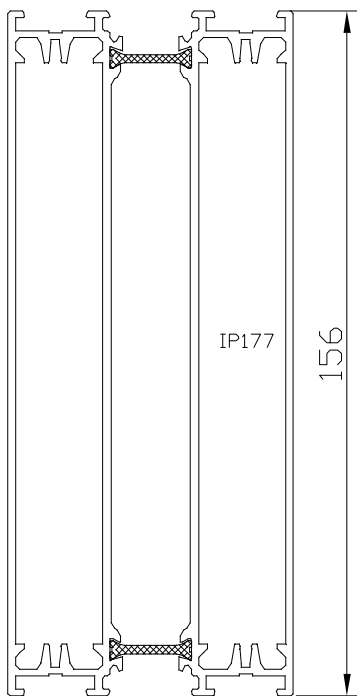

DA-65 EF  
Expander IP177



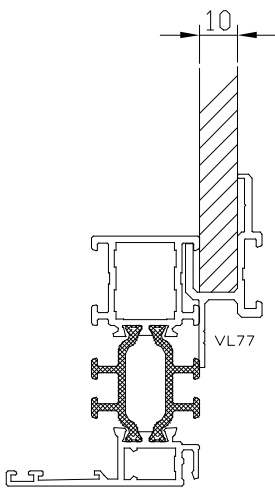

DA-65 EF  
Covering profile VL77

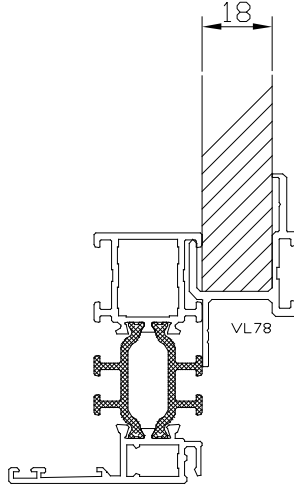

DA-65 EF  
Covering profile VL78

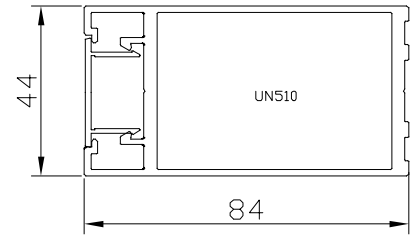

DA-65 EF  
Tube reinforcement UN510

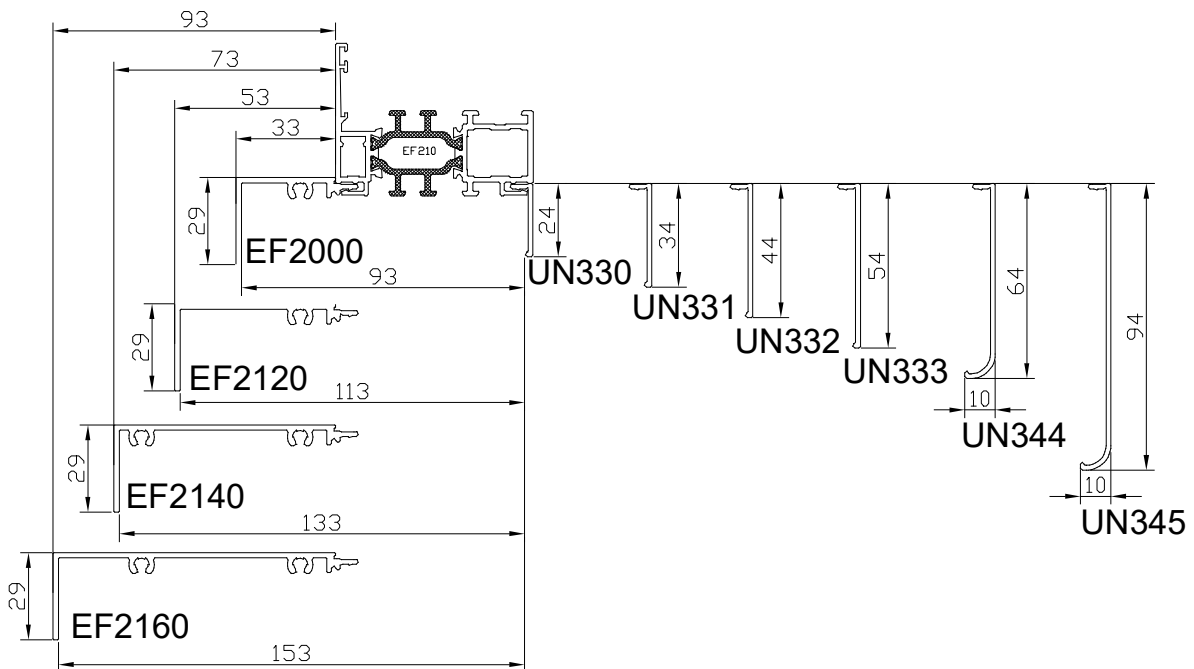

DA-65 EF  
Covering profile for renovation

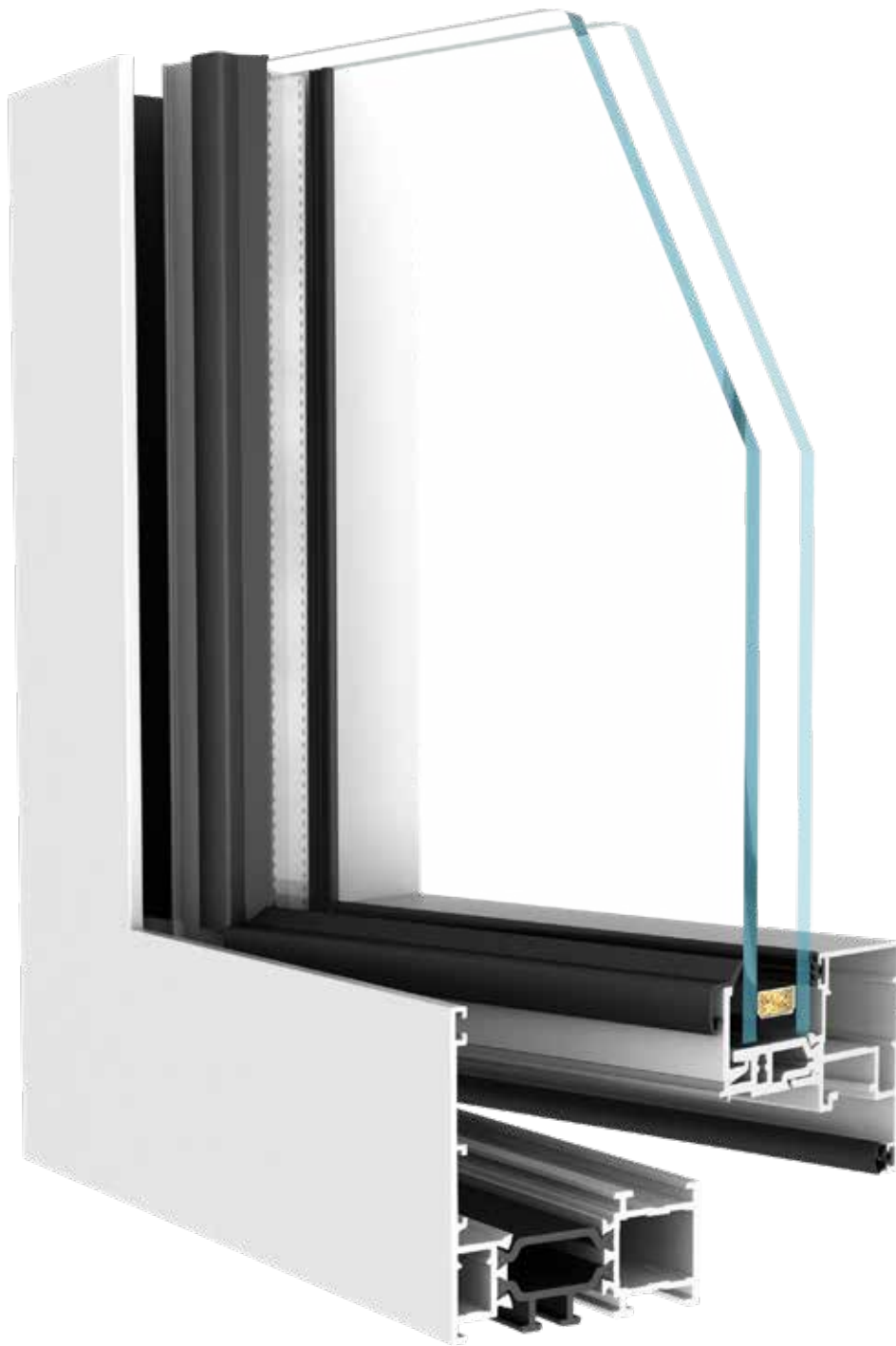

**DA-65 EFUS**

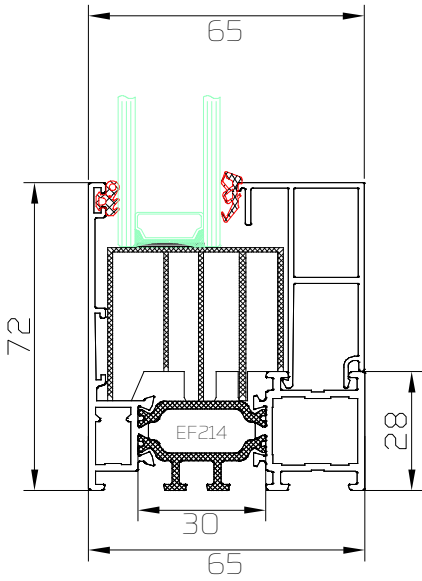

DA-65 EFUS  
Fixed window  
Frame: EF214

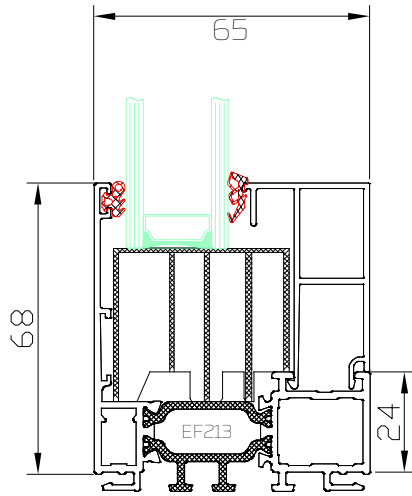

DA-65 EFUS  
Fixed window  
Frame: EF213

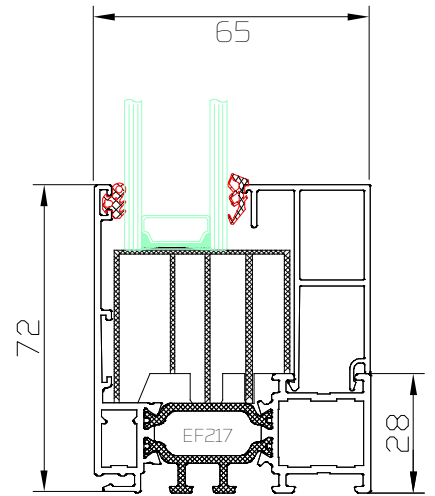

DA-65 EFUS  
Fixed window  
Frame: EF217

DA-65 EFUS  
Fixed window  
Frame: EF215

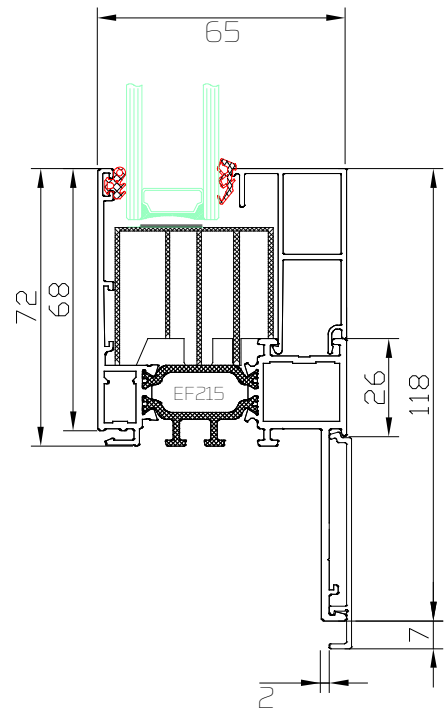

DA-65 EFUS  
Fixed window  
Frame: EF215

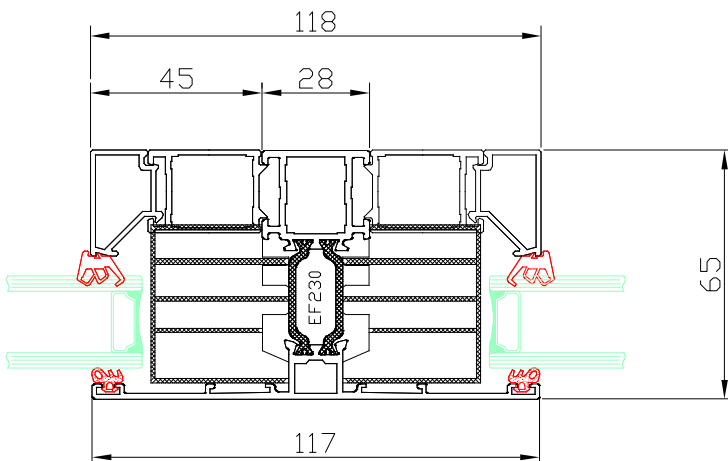

DA-65 EFUS  
Fixed mullion  
Mullion: EF230

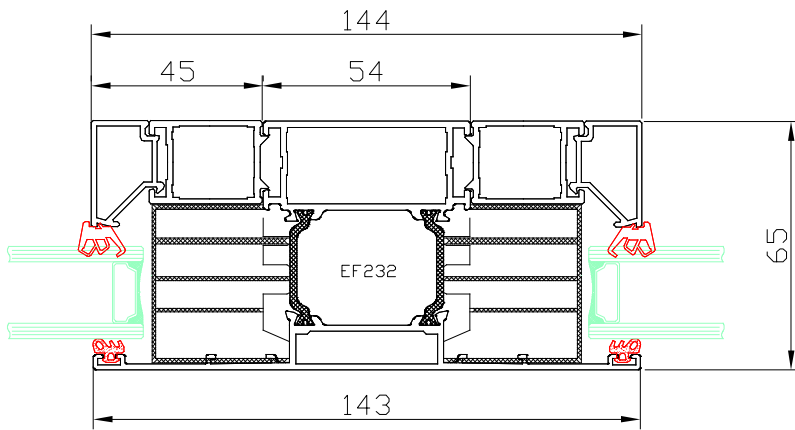

DA-65 EFUS  
Fixed mullion  
Mullion: EF232

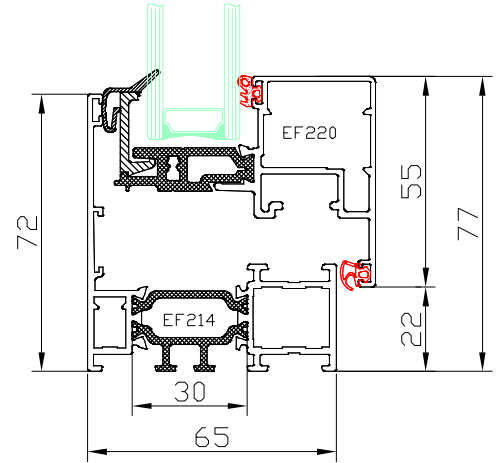

DA-65 EFUS  
Tilt-and-turn window, Turn window  
and Tilt window  
Frame: EF214  
Sash: EF220

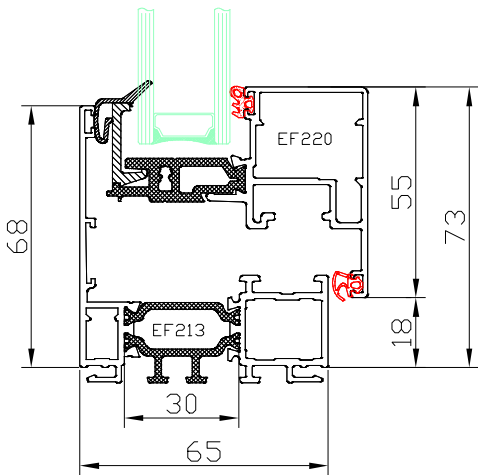

DA-65 EFUS  
Tilt-and-turn window, Turn window  
and Tilt window  
Frame: EF213  
Sash: EF220

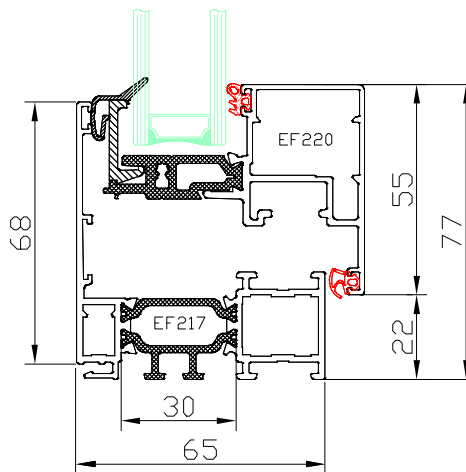

DA-65 EFUS  
Tilt-and-turn window, Turn window  
and Tilt window  
Frame: EF217  
Sash: EF220

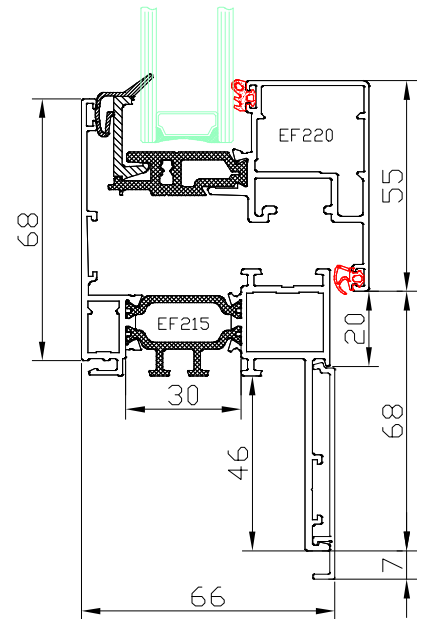

DA-65 EFUS  
Tilt-and-turn window, Turn window  
and Tilt window  
Frame: EF215  
Sash: EF220

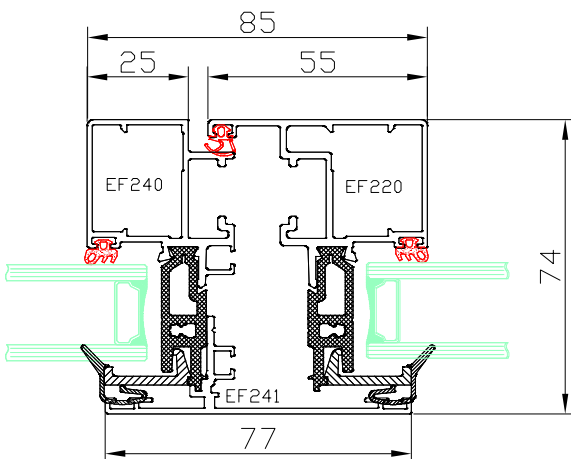

DA-65 EFUS  
Movable mullion  
Mullion: EF241  
Sash: EF220 i EF240

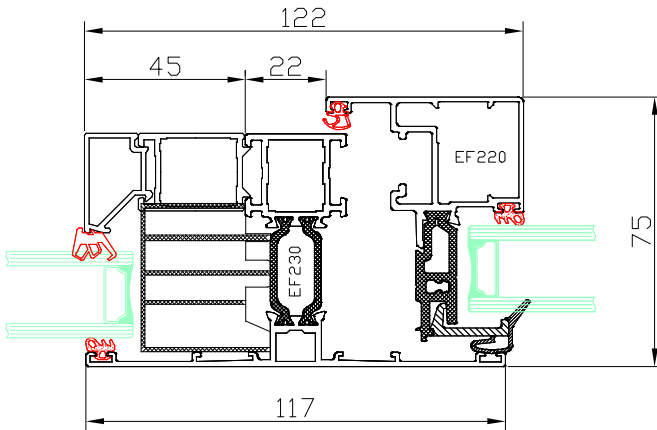

|   |
|---|
| DA-65 EFUS  |
| Mullion for Tilt-and-turn window and fixed window |
| Sash: EF220                                       |
| Mullion: EF230                                    |

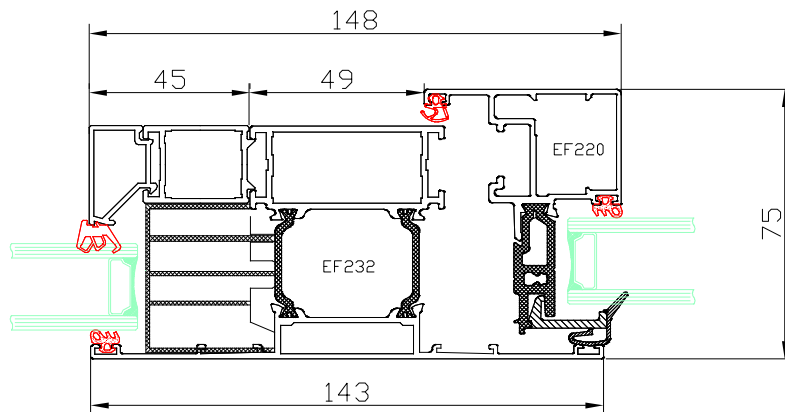

|   |
|---|
| DA-65 EFUS  |
| Mullion for Tilt-and-turn window and fixed window |
| Sash: EF220                                       |
| Mullion: EF232                                    |

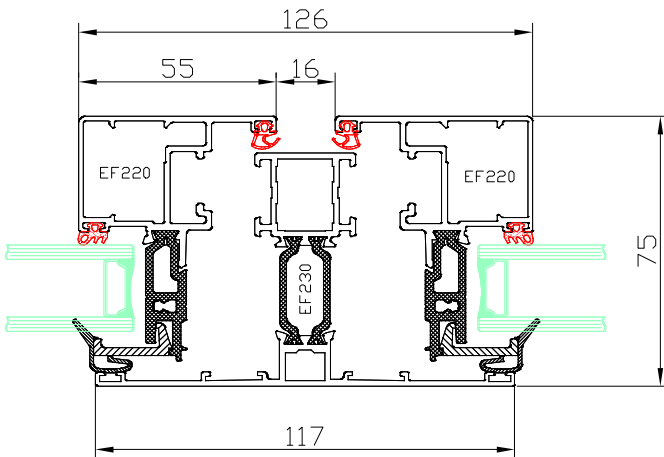

|                                    |
|------------------------------------|
| DA-65 EFUS                         |
| 2 sash window with a fixed mullion |
| Mullion: EF230                     |
| Sash: EF220                        |

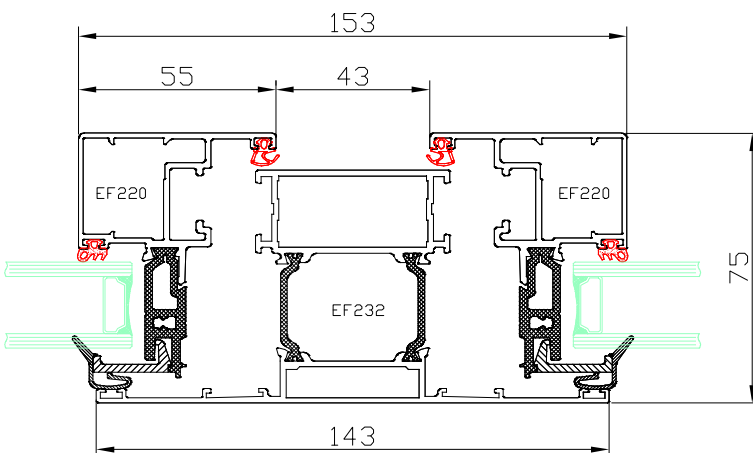

|                                    |
|------------------------------------|
| DA-65 EFUS                         |
| 2 sash window with a fixed mullion |
| Mullion: EF232                     |
| Sash: EF220                        |

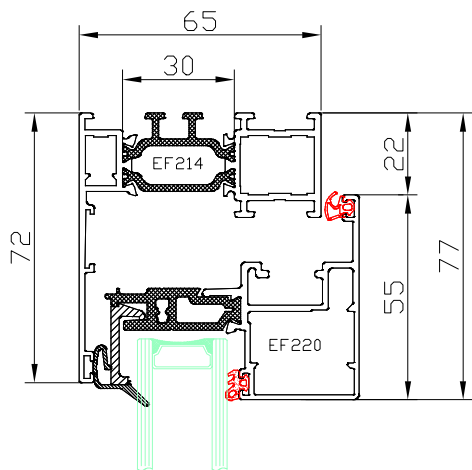

|                           |
|---------------------------|
| DA-65 EFUS                |
| 1 or 2-sash balcony doors |
| Frame: EF214              |
| Sash: EF220               |

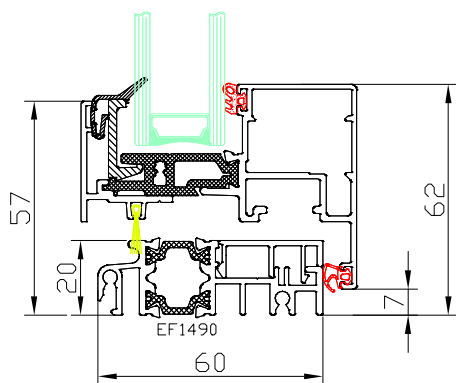

|                           |
|---------------------------|
| DA-65 EFUS                |
| 1 or 2-sash balcony doors |
| Sash: E2720               |
| Threshold: EF1490         |

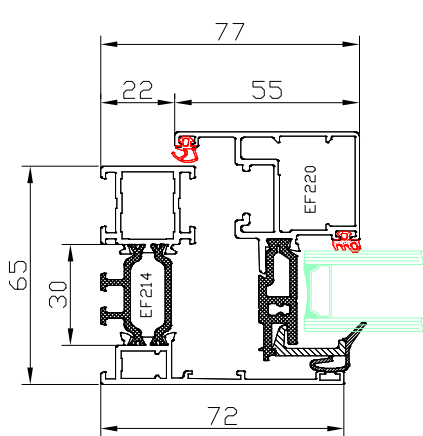
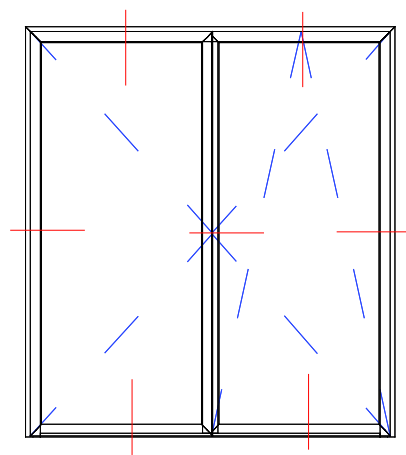

|                           |
|---------------------------|
| DA-65 EFUS                |
| 1 or 2-sash balcony doors |
| Frame: EF214              |
| Sash: EF220               |

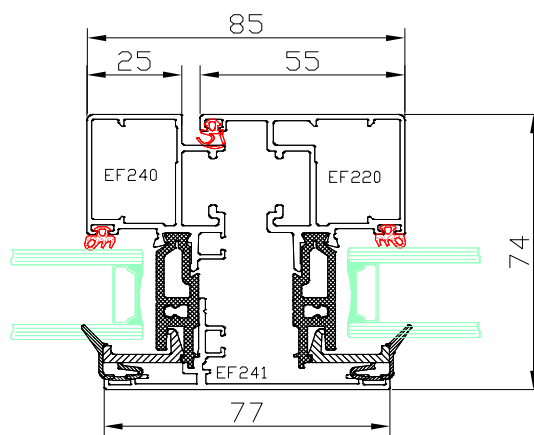

|                           |
|---------------------------|
| DA-65 EFUS                |
| 1 or 2-sash balcony doors |
| Mullion: EF241            |
| Sash: EF220   EF240       |

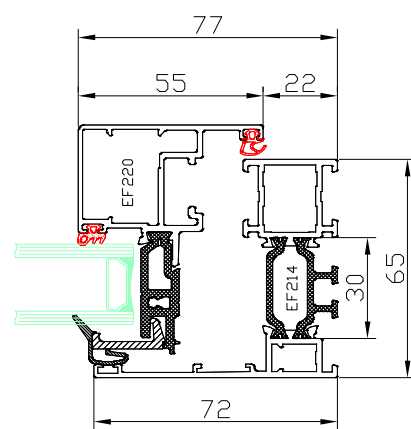

|                           |
|---------------------------|
| DA-65 EFUS                |
| 1 or 2-sash balcony doors |
| Frame: EF214              |
| Sash: EF220               |

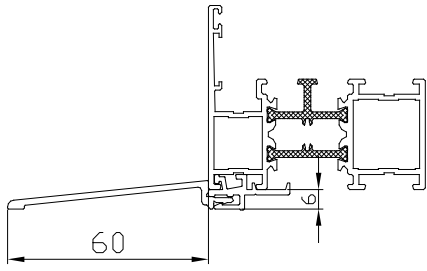

DA-65 EFUS  
Sill profile (window sill) UN320 + UN119

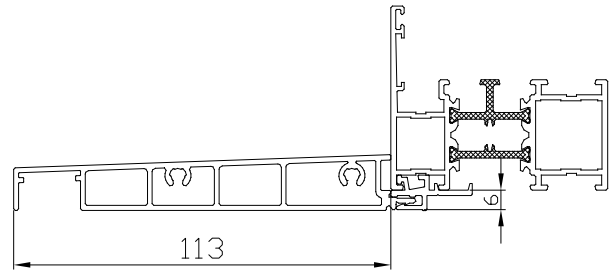

DA-65 EFUS  
Sill profile (window sill) EF2000 + UN119

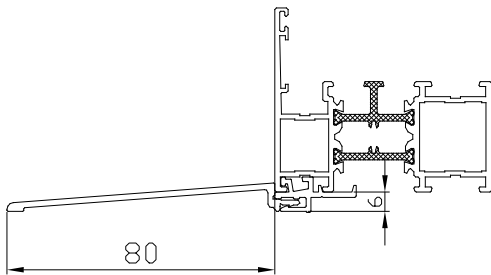

DA-65 EFUS  
Sill profile (window sill) UN321 + UN119

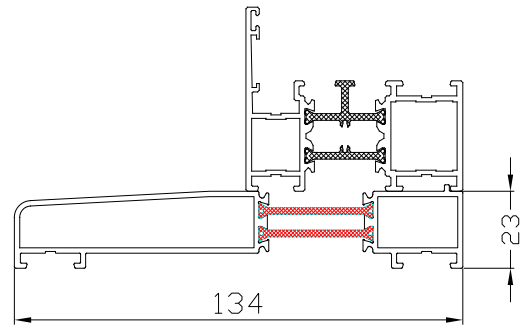

DA-65 EFUS  
Sill profile (window sill) IN357

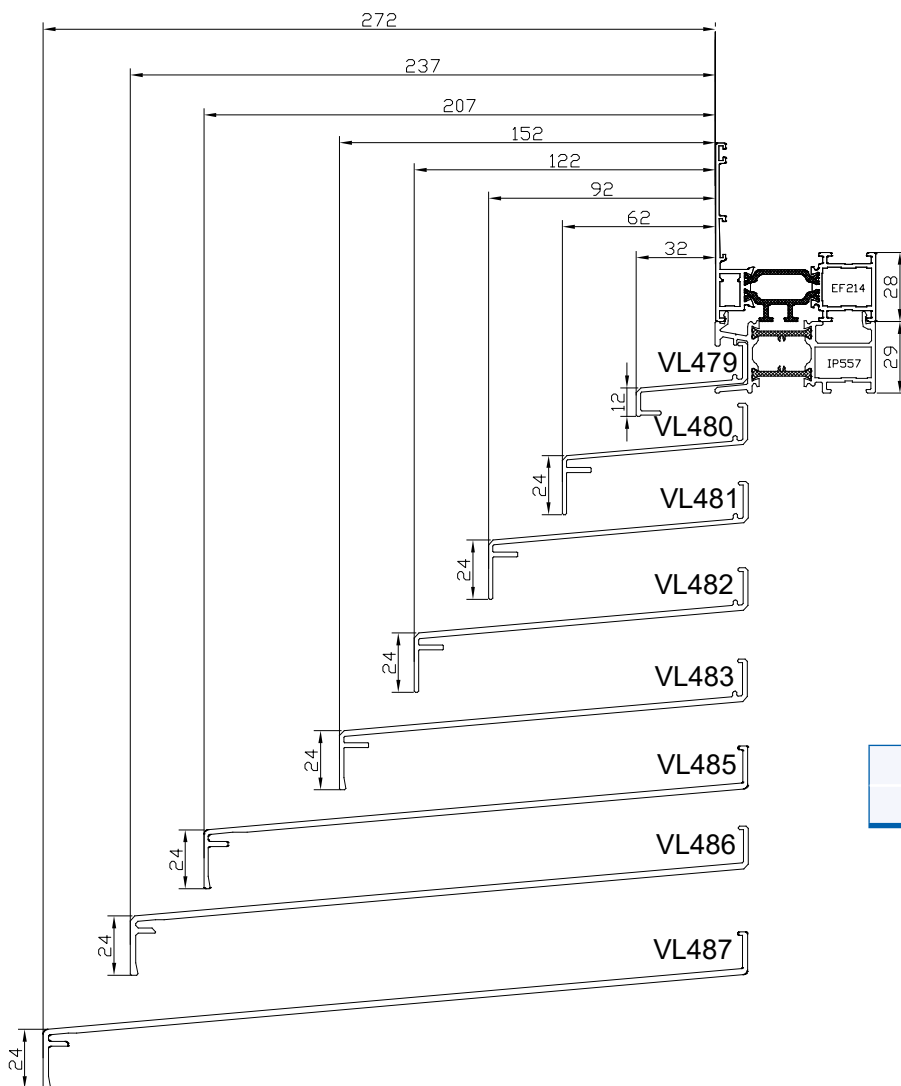

DA-65 EFUS  
Sill profile (window sill)

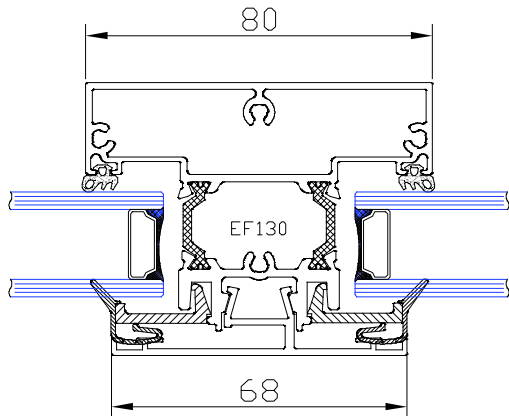

DA-65 EFUS  
Crossbar in the sash

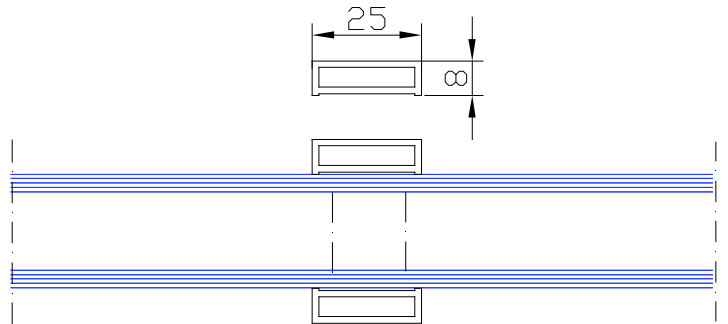

DA-65 EFUS  
Glued-on muntin bars + DUPLEX:  
inter-pane muntin bars

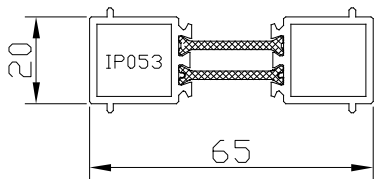

DA-65 EFUS  
Connector IP053

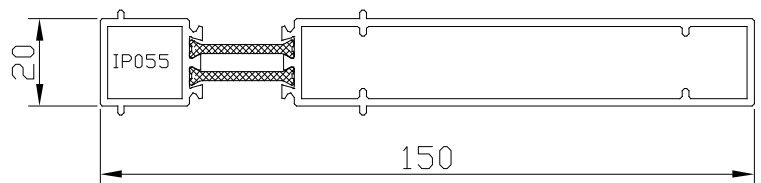

DA-65 EFUS  
Connector IP055

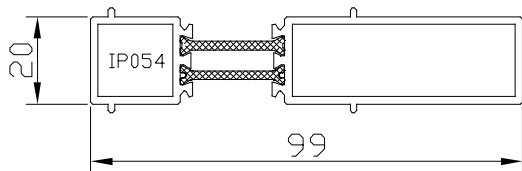

DA-65 EFUS  
Connector IP054

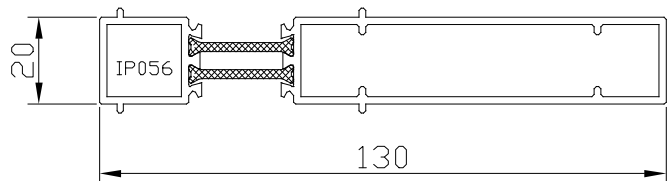

DA-65 EFUS  
Connector IP056



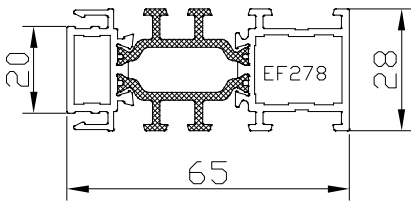

DA-65 EFUS  
Expansion Joint EF278

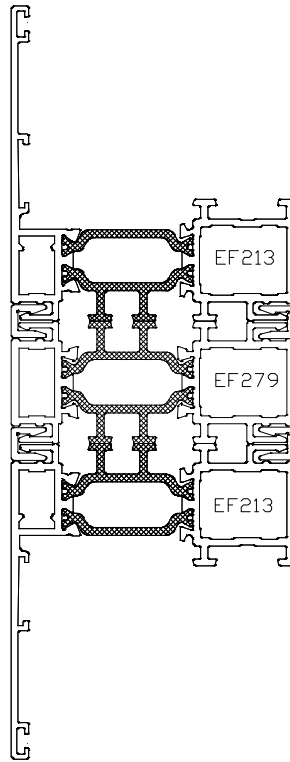

DA-65 EFUS  
Expansion Joints EF279 (example)

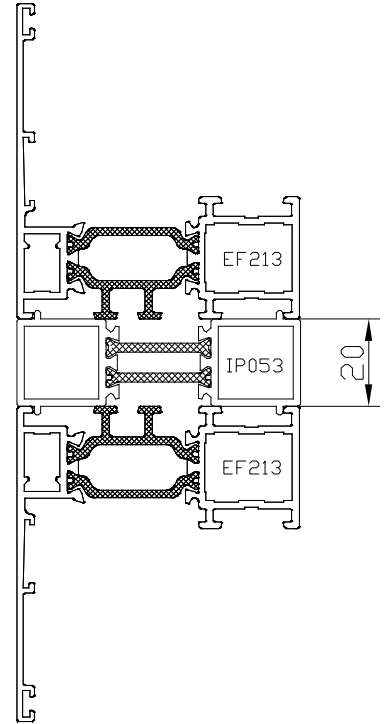

DA-65 EFUS  
Connectors IP053 (example)

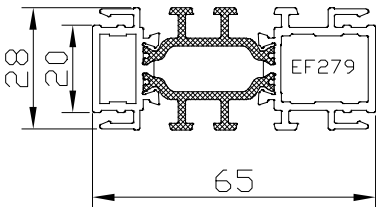

DA-65 EFUS  
Expansion Joint EF279

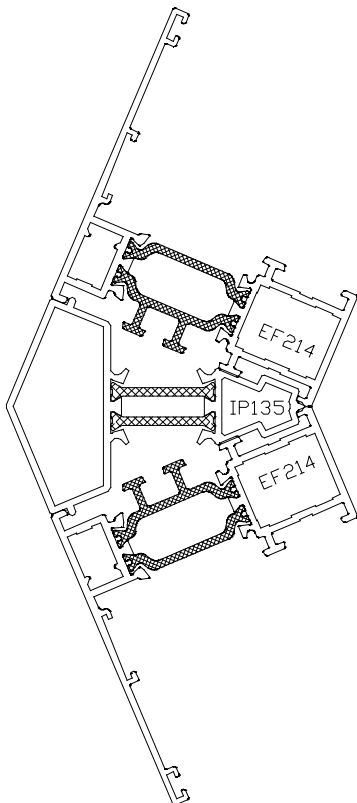

DA-65 EFUS  
Corner joint IP135

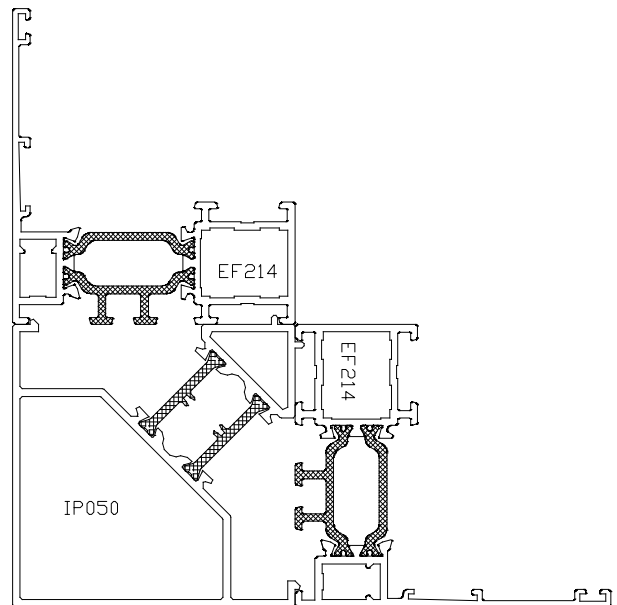

DA-65 EFUS  
Corner joint IP050

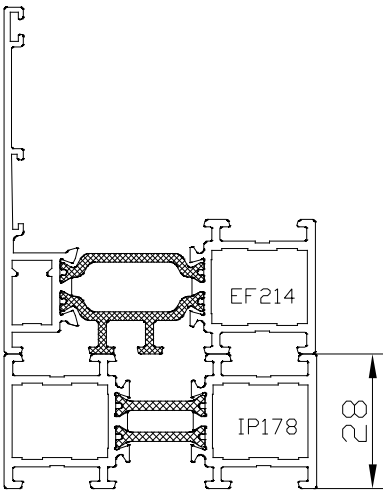

DA-65 EFUS  
Expander IP178 (example)

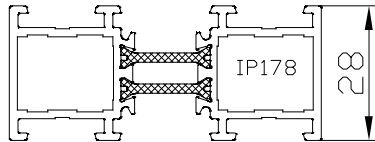

DA-65 EFUS  
Expander IP178

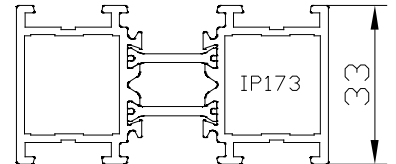

DA-65 EFUS  
Expander IP173

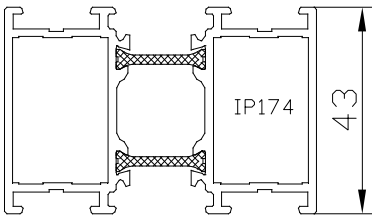

DA-65 EFUS  
Expander IP174

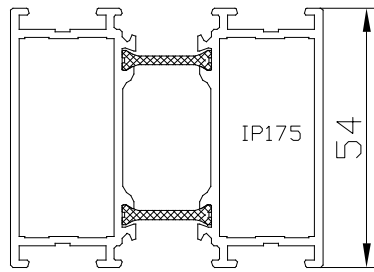

DA-65 EFUS  
Expander IP175

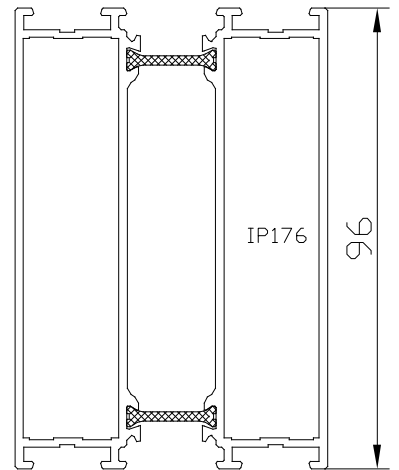

DA-65 EFUS  
Expander IP176

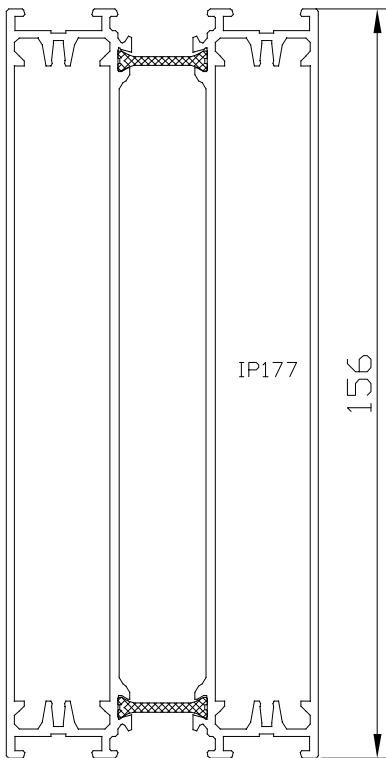

DA-65 EFUS  
Expander IP177

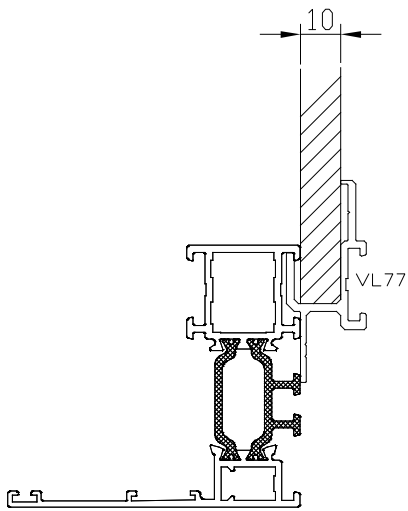

DA-65 EFUS  
Covering profile VL77

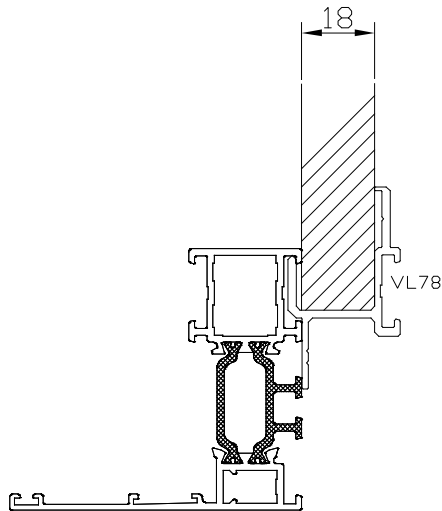

DA-65 EFUS  
Covering profile VL78

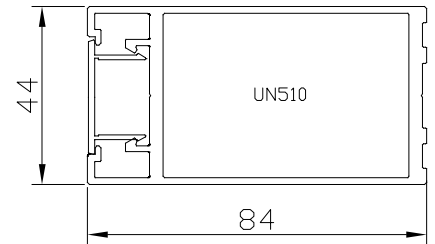

DA-65 EFUS  
Tube reinforcement UN510

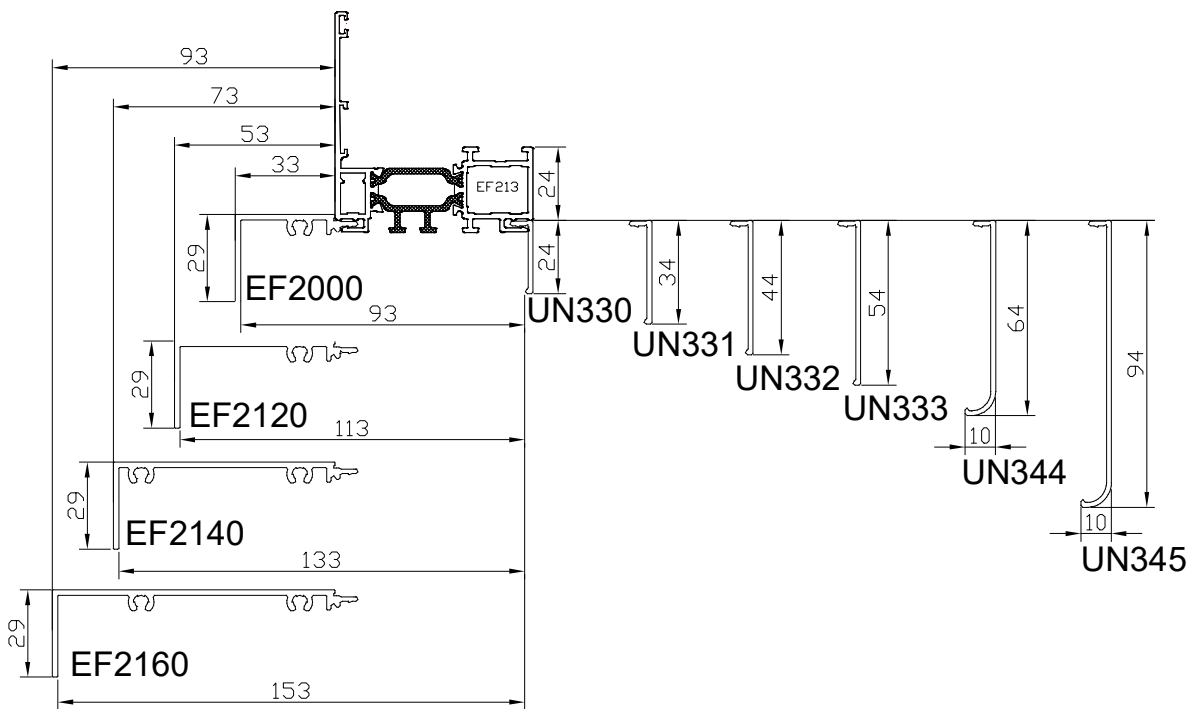

DA-65 EFUS  
Covering profile for renovation

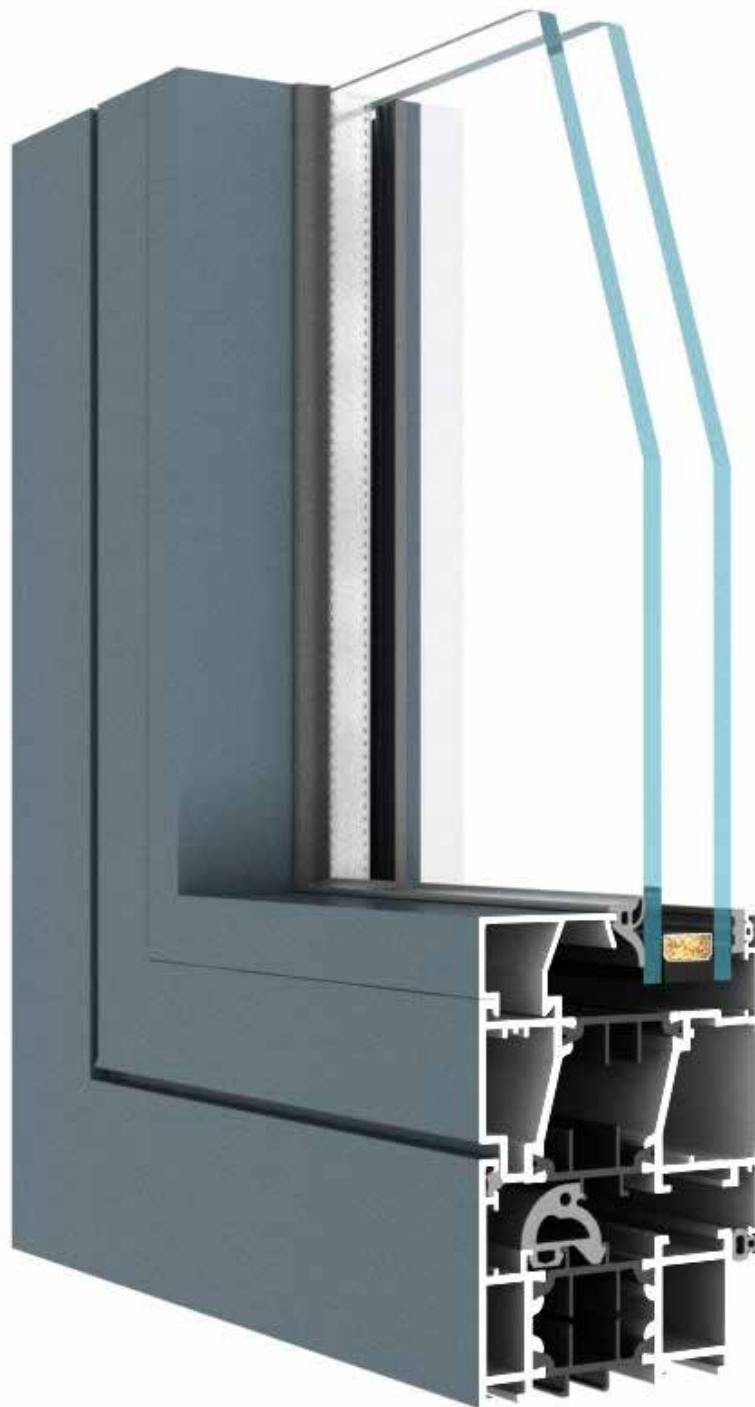

DA-70C

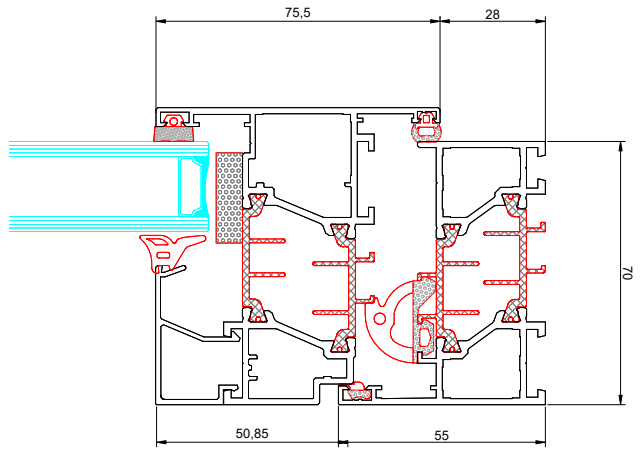
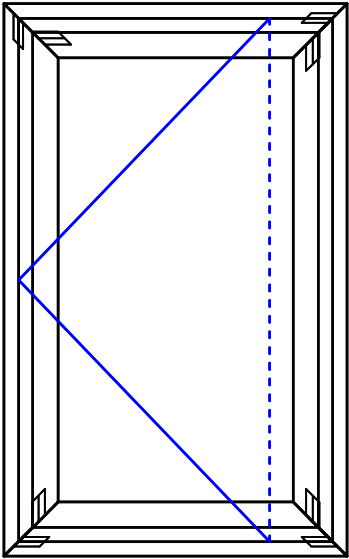

DA-70C SIDE HUNG

Frame: K518474

Sash: K518472

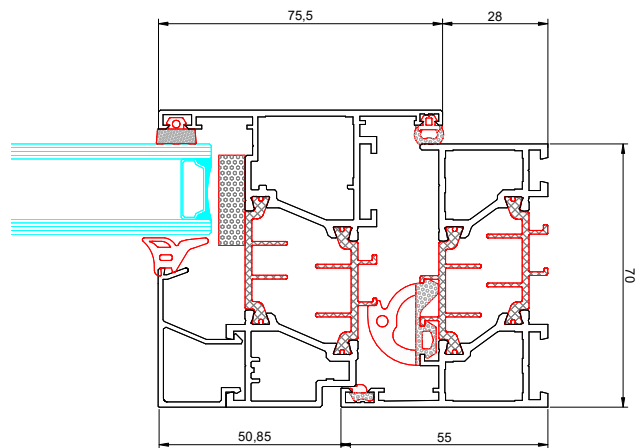
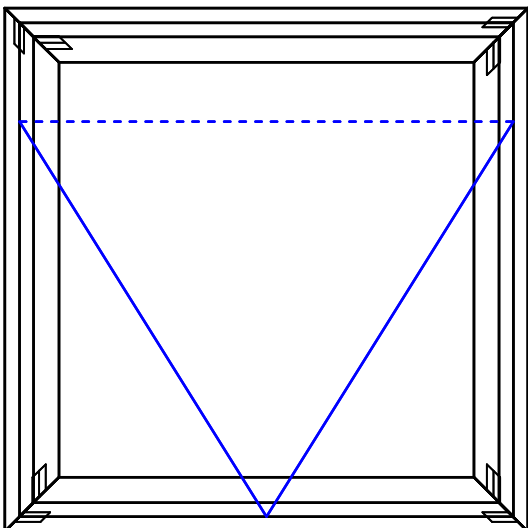

DA-70C TOP HUNG

Frame: K518474

Sash: K518472

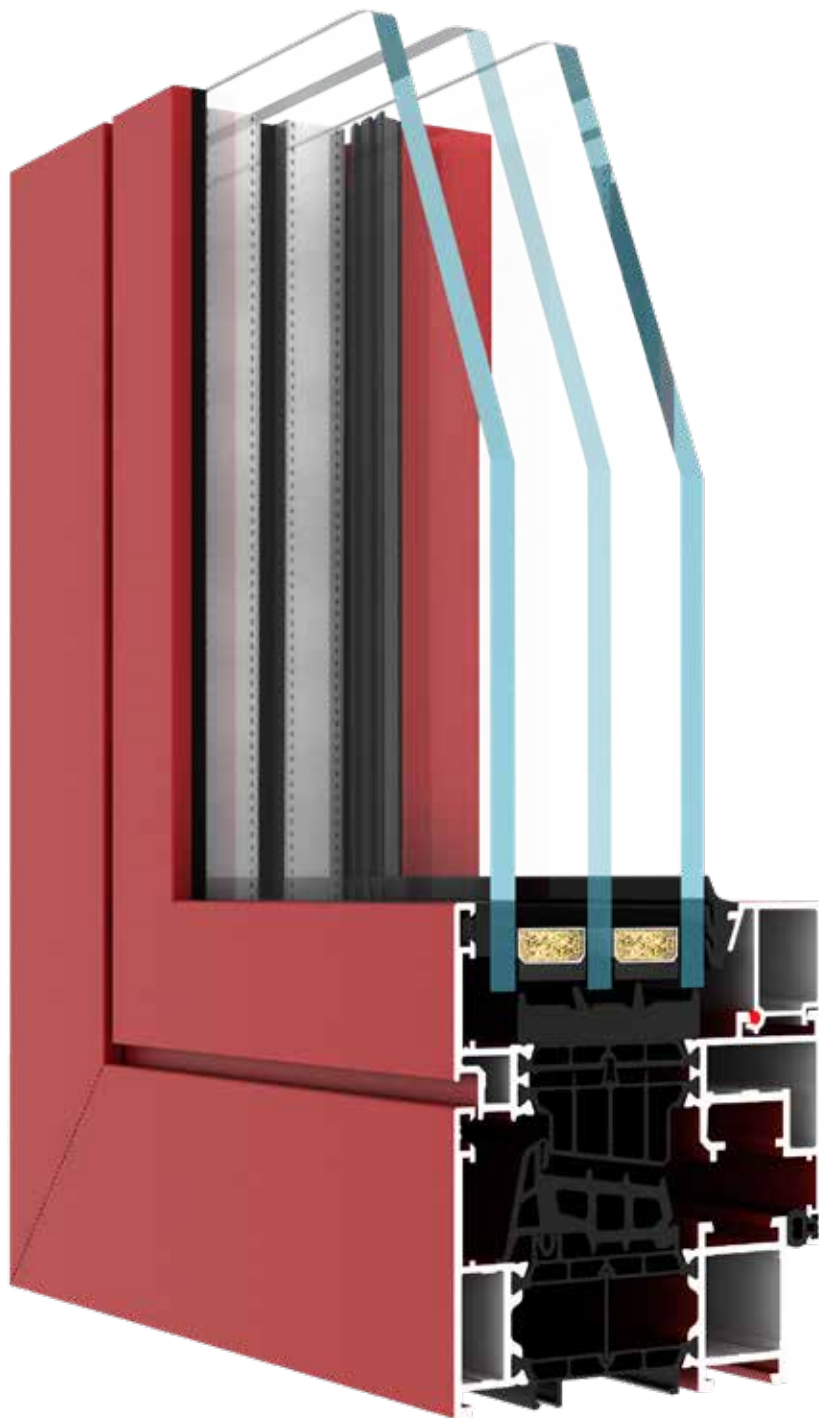

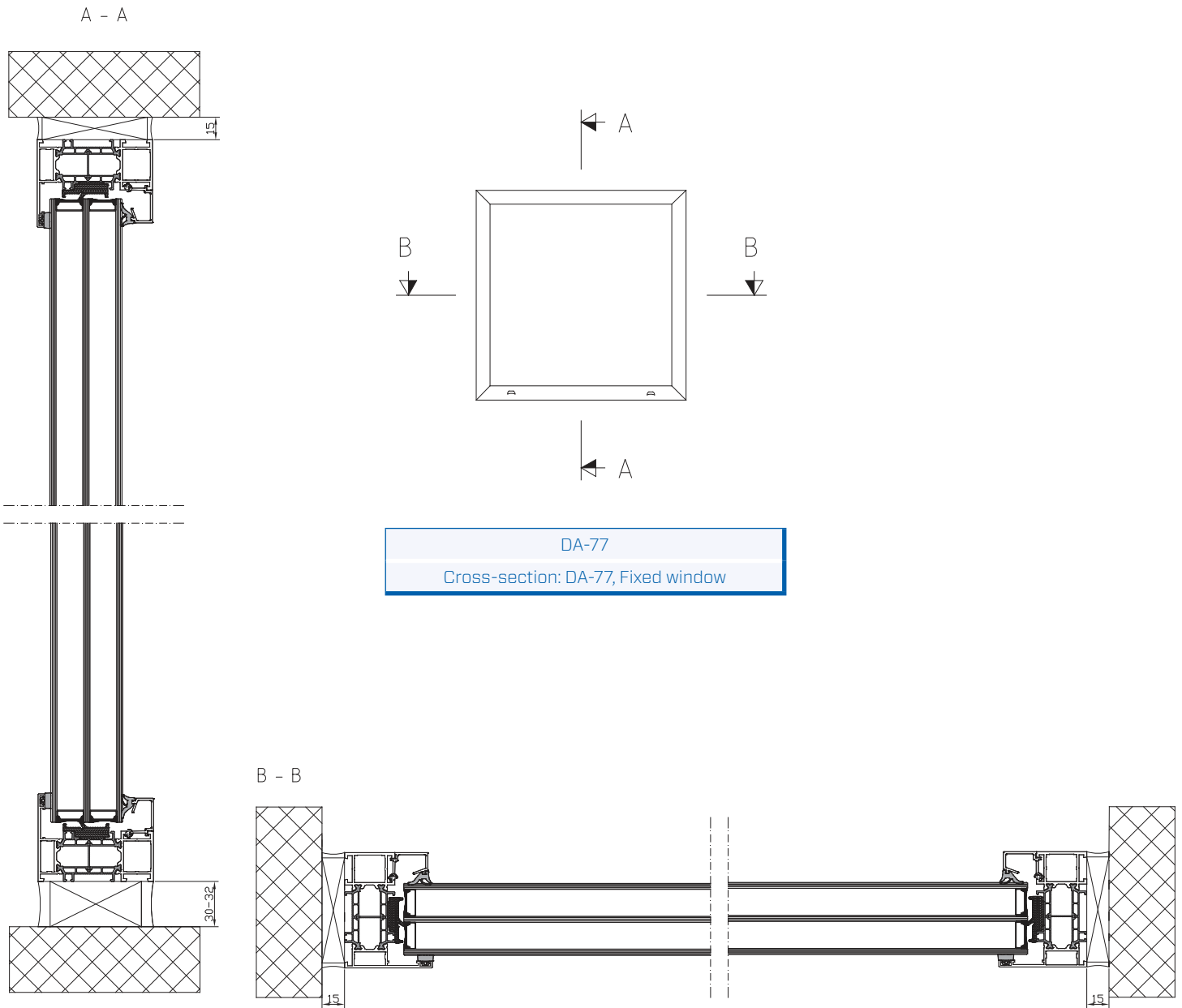

CROSS-SECTION A-A AND B-B

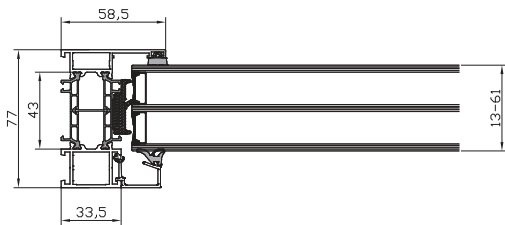

DA-77 FW.01

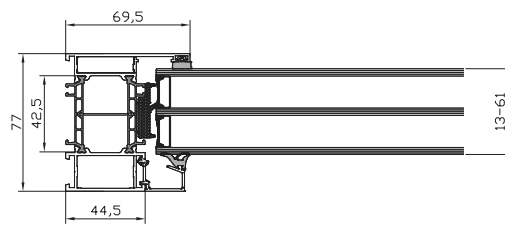

DA-77 FW.02

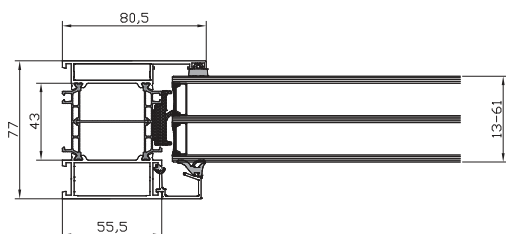

DA-77 FW.03

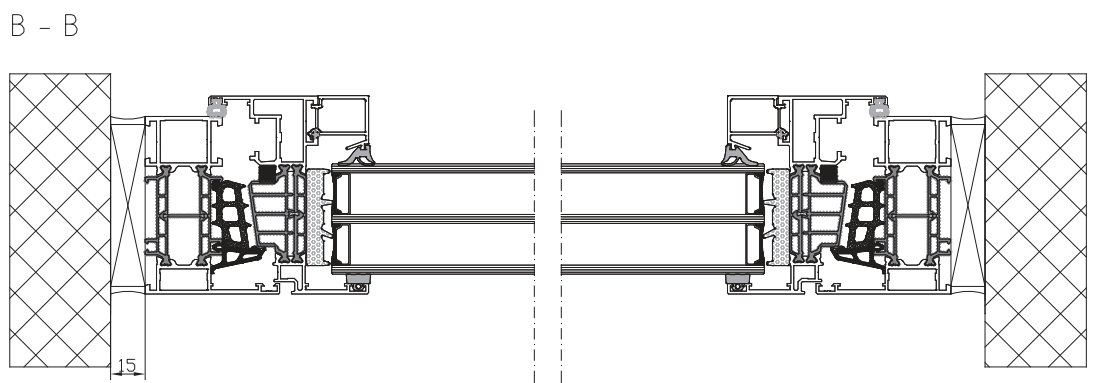
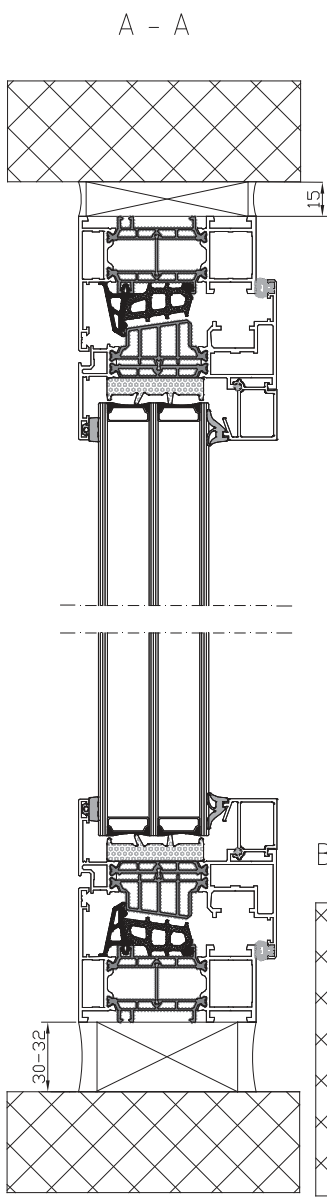
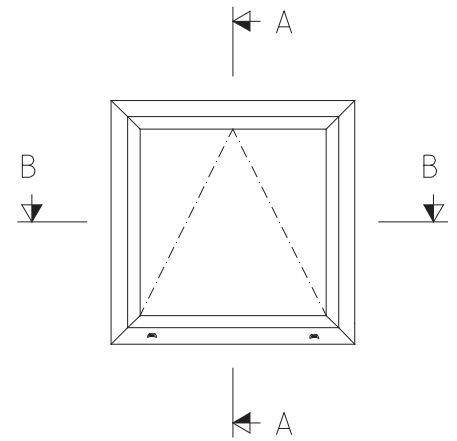
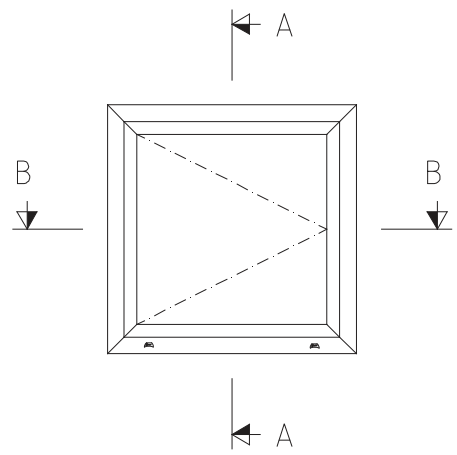
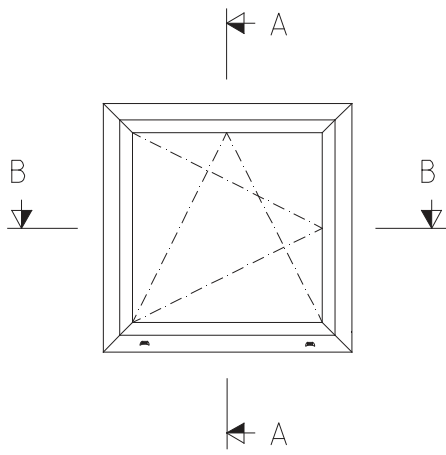

DA-77  
Cross-section: DA-77, 1-sash window



CROSS-SECTION A-A AND B-B

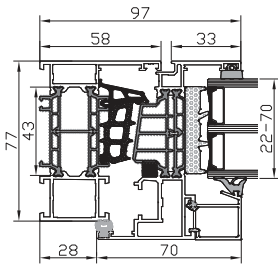

DA-77 FW.01/SW.01

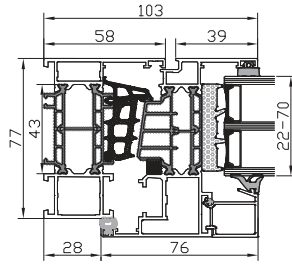

DA-77 FW.01/SW.02

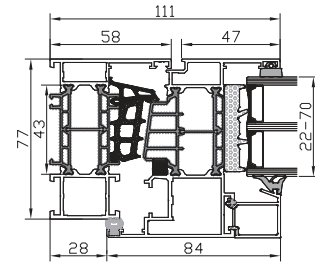

DA-77 FW.01/SW.03

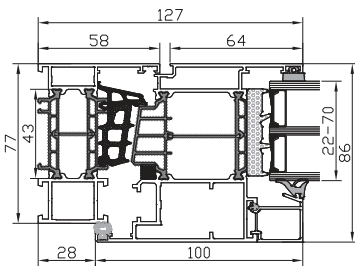

DA-77 FW.01/SW.04

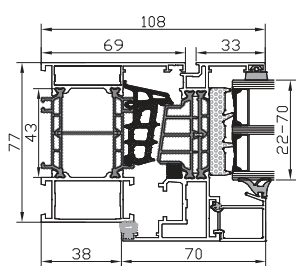

DA-77 FW.02/SW.01

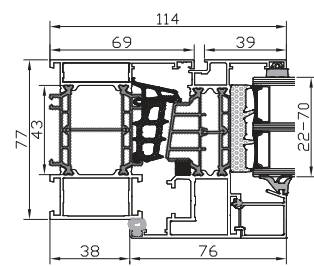

DA-77 FW.02/SW.02

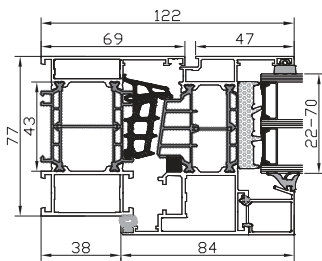

DA-77 FW.02/SW.03

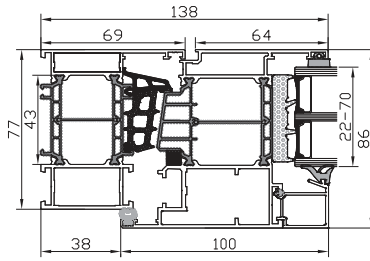

DA-77 FW.02/SW.04

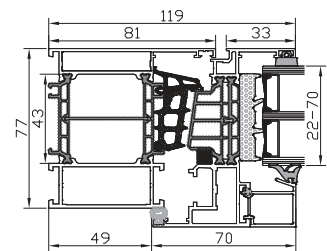

DA-77 FW.03/SW.01

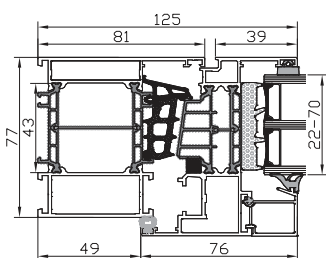

DA-77 FW.03/SW.02

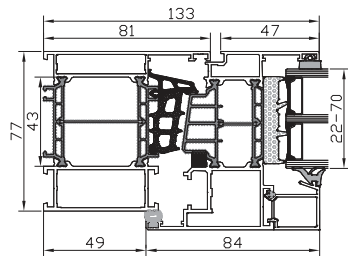

DA-77 FW.03/SW.03

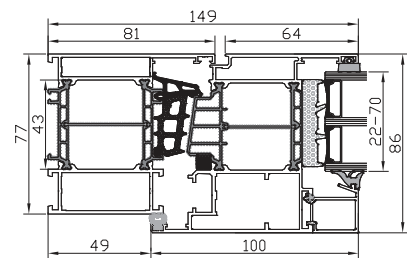

DA-77 FW.03/SW.04

A - A

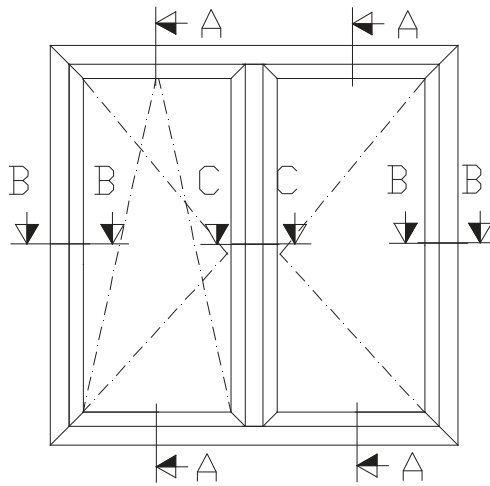
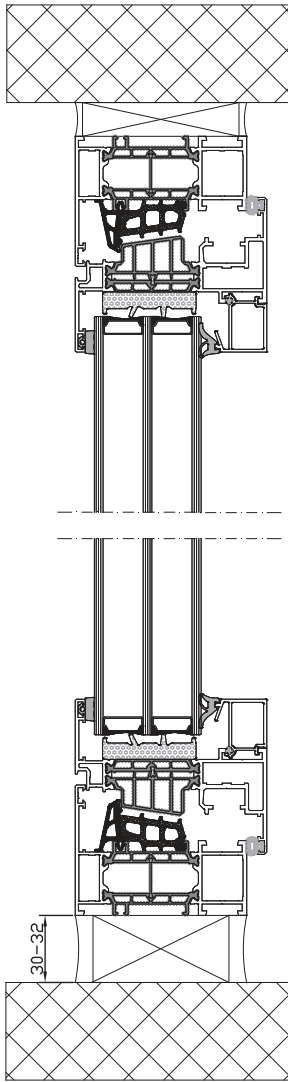

DA-77  
 Cross-section: DA-77, window with a movable mullion

B - B

C - C

B - B

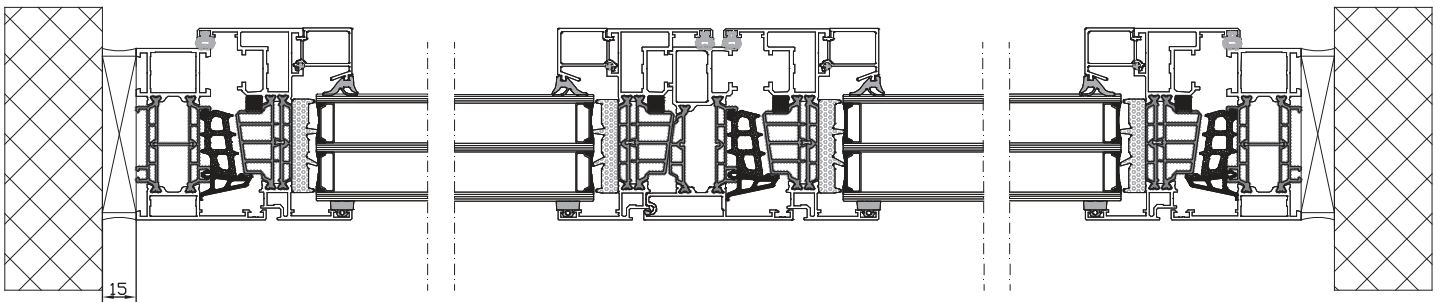

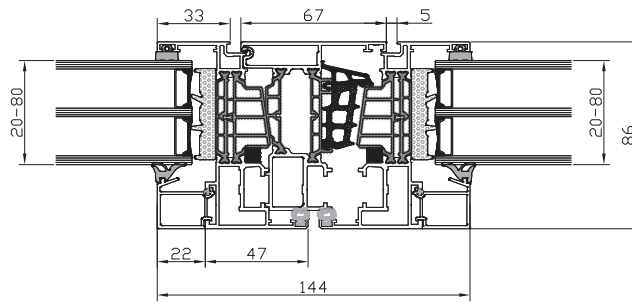

DA-77 SW.01/MP.01/SW.01

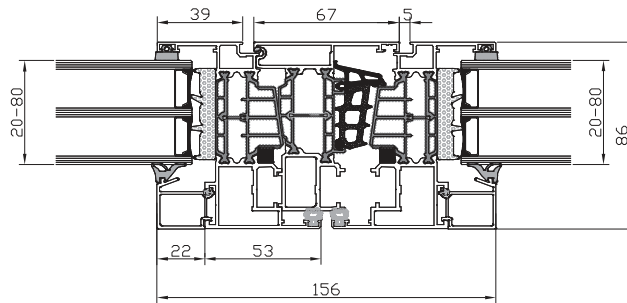

DA-77 SW.02/MP.01/SW.02

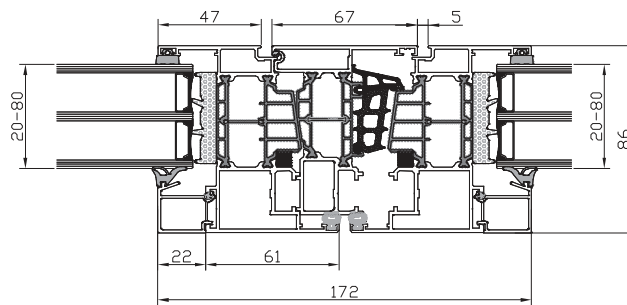

DA-77 SW.03/MP.01/SW.03

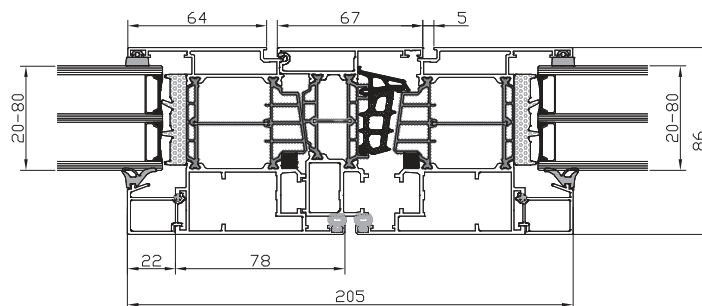

DA-77 SW.04/MP.01/SW.04

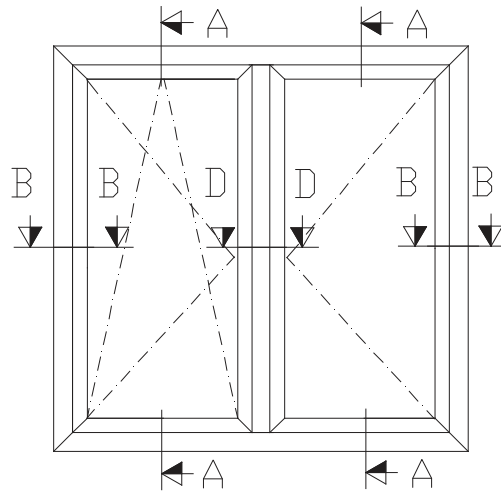
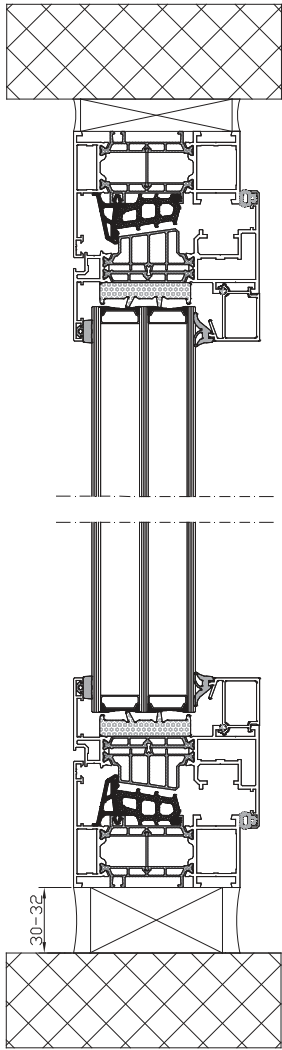

DA-77  
 Cross-section: DA-77, tilt-and-turn window with  
 a fixed window

B - B

D - D

B - B

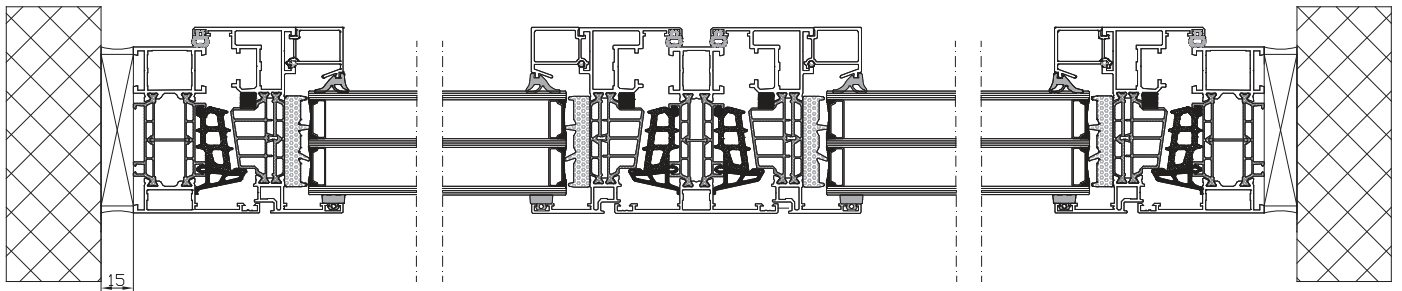

CROSS-SECTION D-D

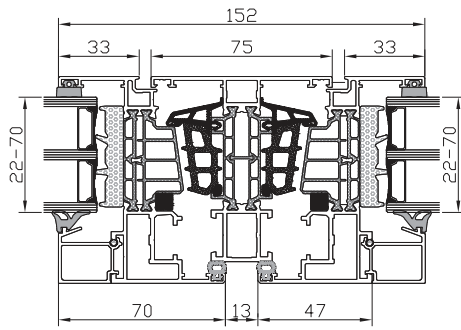

DA-77 SW.01/PP.01/SW.01

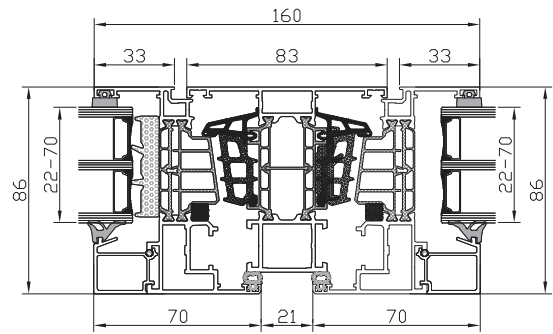

DA-77 SW.01/PP.02/SW.01

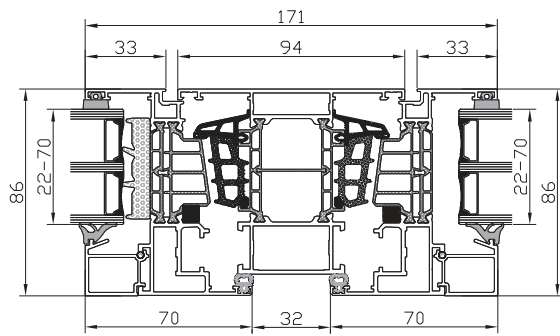

DA-77 SW.01/PP.03/SW.01

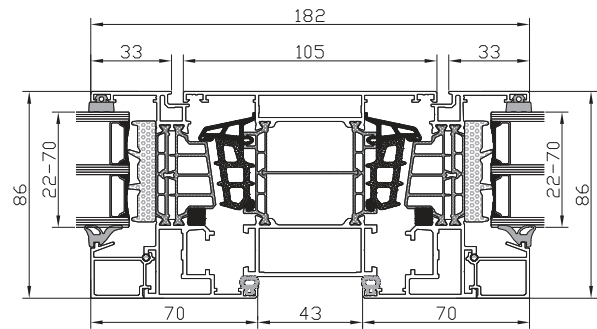

DA-77 SW.01/PP.04/SW.01

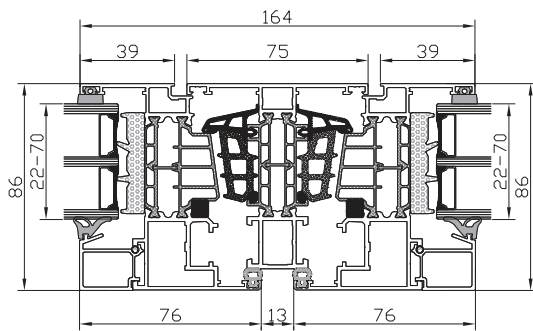

DA-77 SW.02/PP.01/SW.02

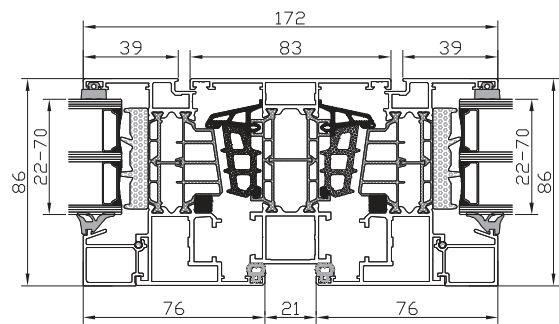

DA-77 SW.02/PP.02/SW.02

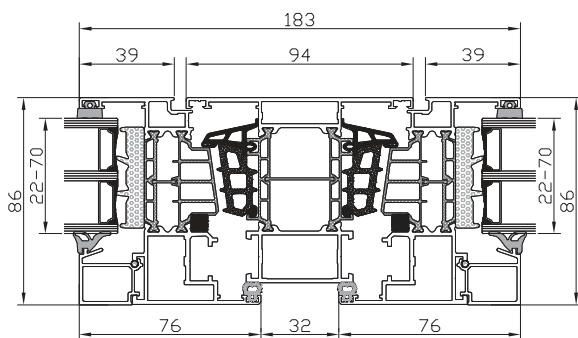

DA-77 SW.02/PP.03/SW.02

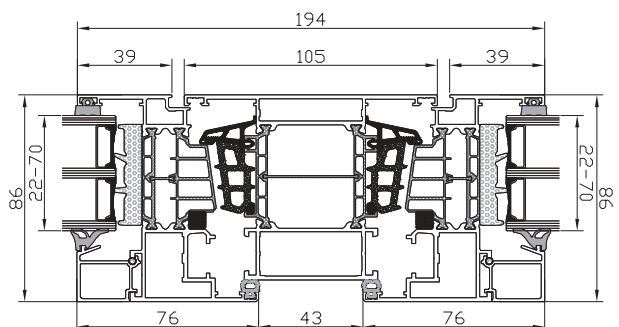

DA-77 SW.02/PP.04/SW.02

CROSS-SECTION D-D

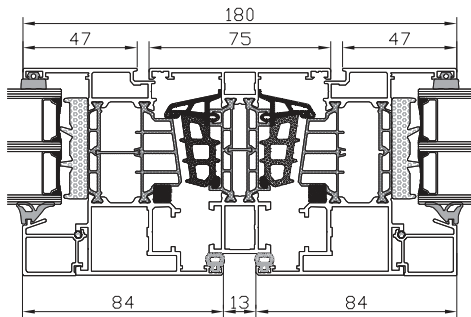

DA-77 SW.03/PP.01/SW.03

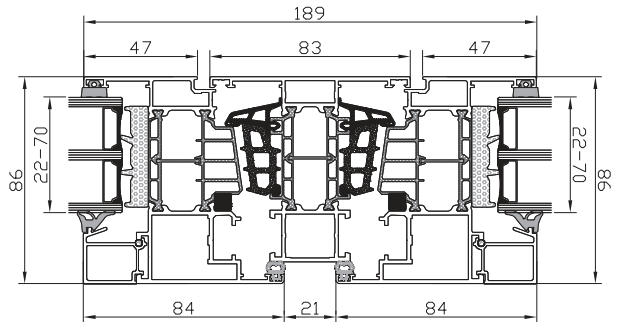

DA-77 SW.03/PP.02/SW.03

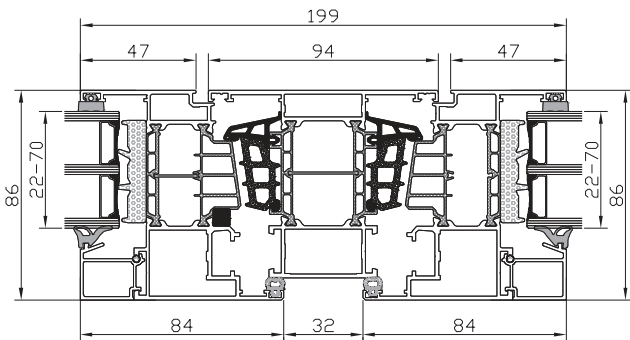

DA-77 SW.03/PP.03/SW.03

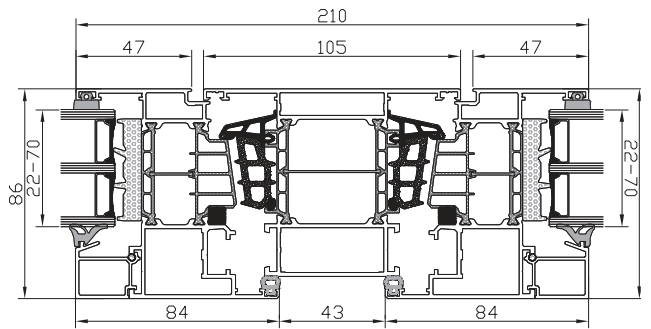

DA-77 SW.03/PP.04/SW.03

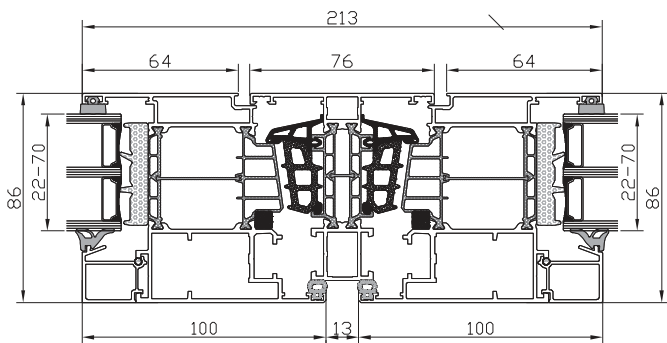

DA-77 SW.04/PP.01/SW.04

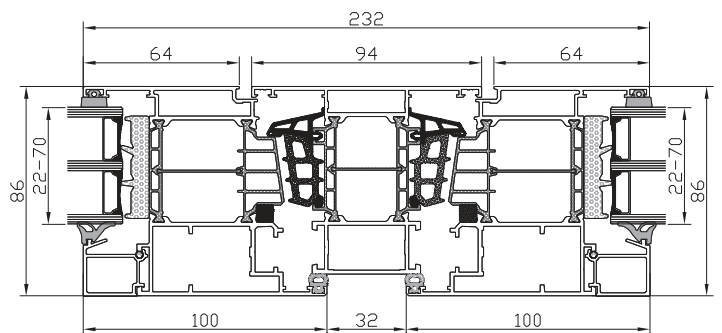

DA-77 SW.04/PP.03/SW.04

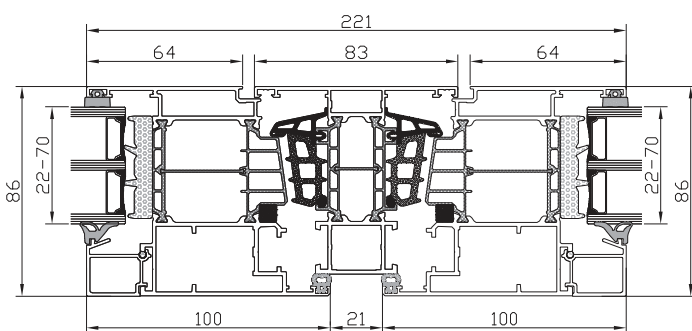

DA-77 SW.04/PP.02/SW.04

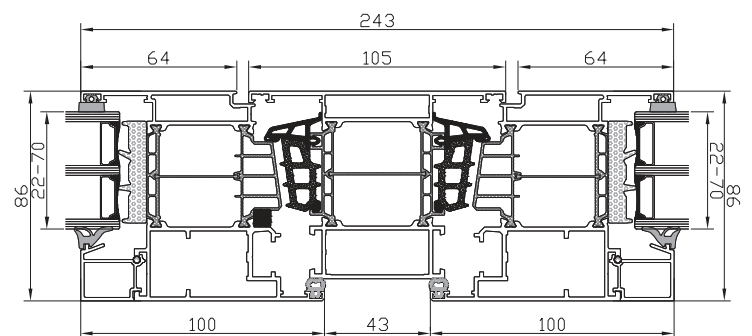

DA-77 SW.04/PP.04/SW.04

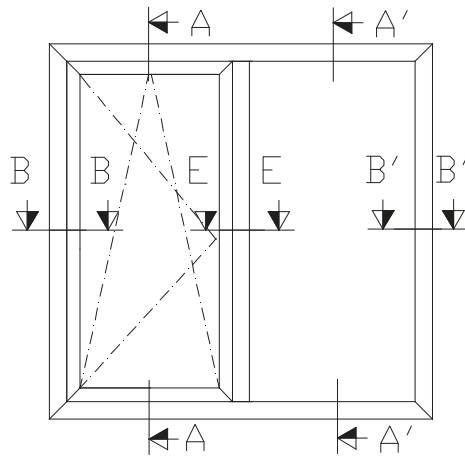
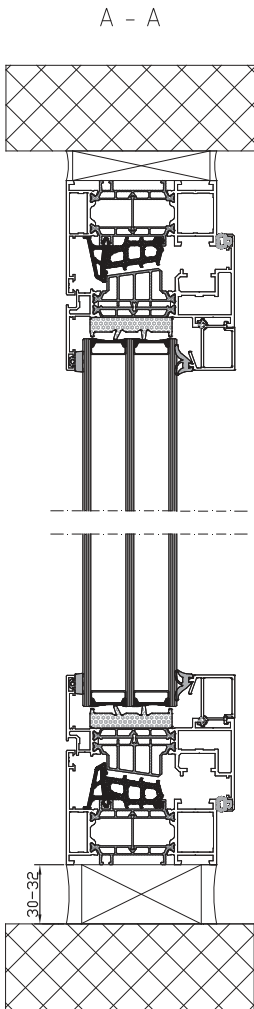

DA-77  
 Cross-section: DA-77, tilt-and-turn window with  
 a fixed window

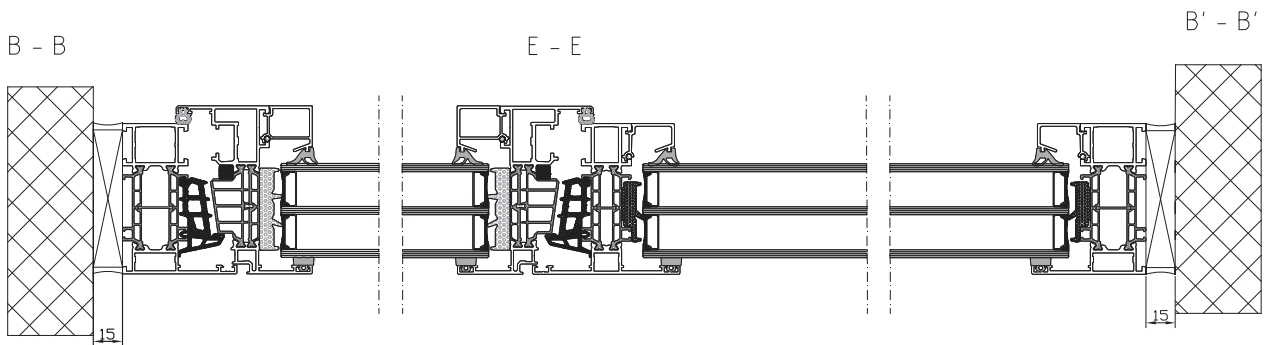

## CROSS-SECTION E-E

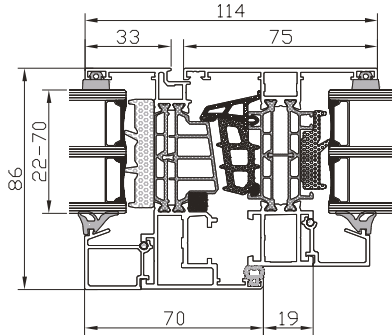

DA-77 SW.01/PP.01

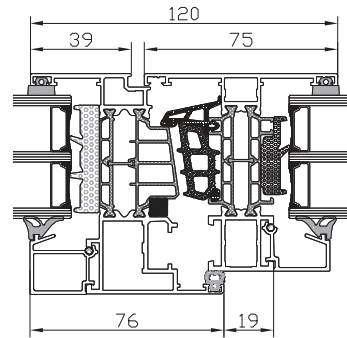

DA-77 SW.02/PP.01

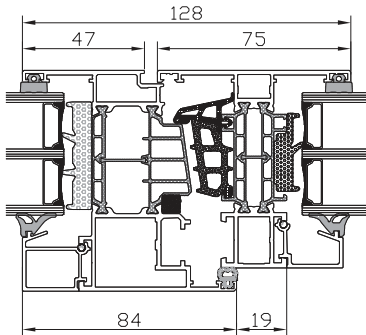

DA-77 SW.03/PP.01

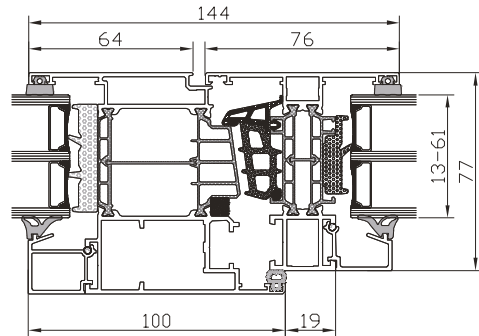

DA-77 SW.04/PP.01

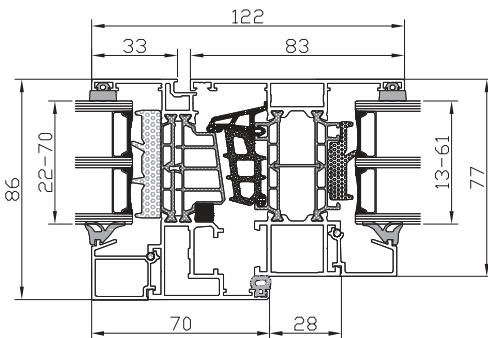

DA-77 SW.01/PP.02

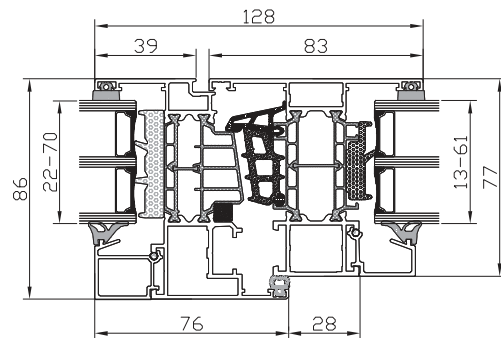

DA-77 SW.02/PP.02

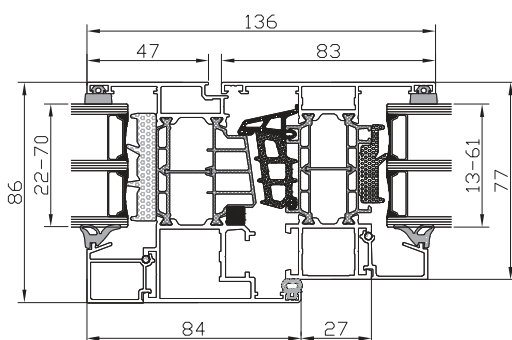

DA-77 SW.03/PP.02

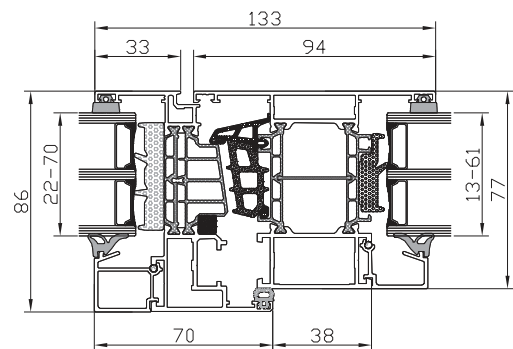

DA-77 SW.01/PP.03



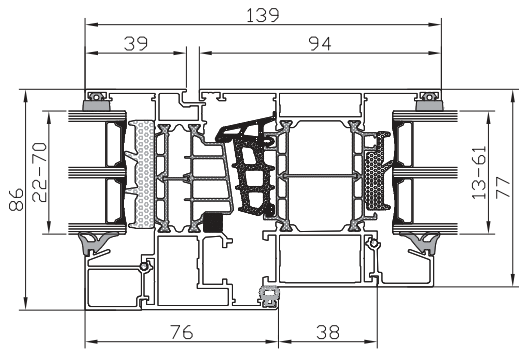

DA-77 SW.02/PP.03

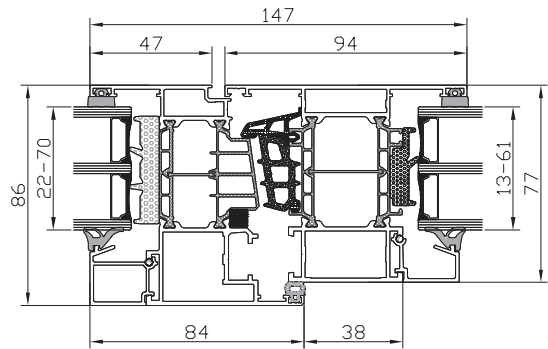

DA-77 SW.03/PP.03

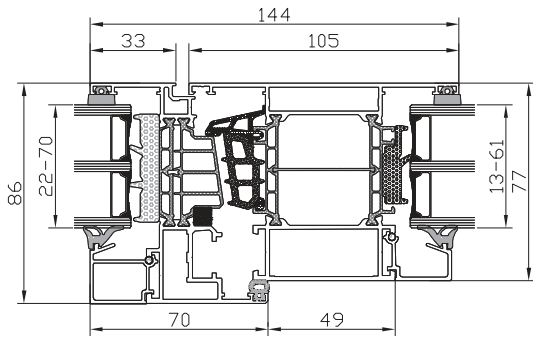

DA-77 SW.01/PP.04

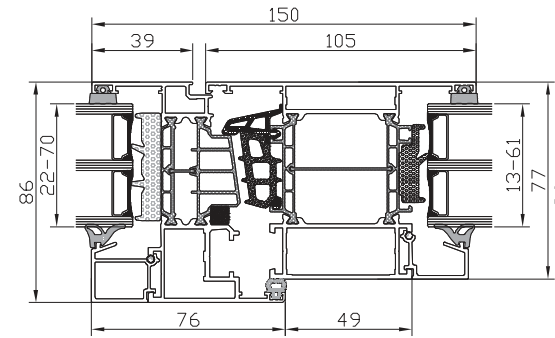

DA-77 SW.02/PP.04

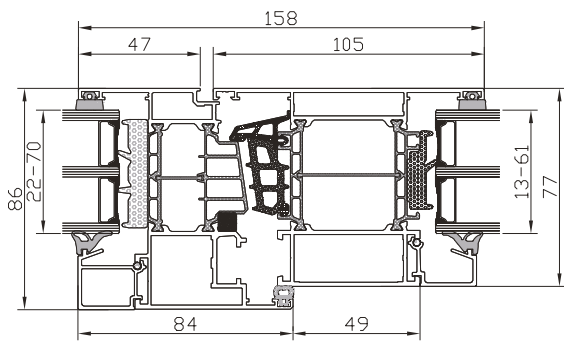

DA-77 SW.03/PP.04

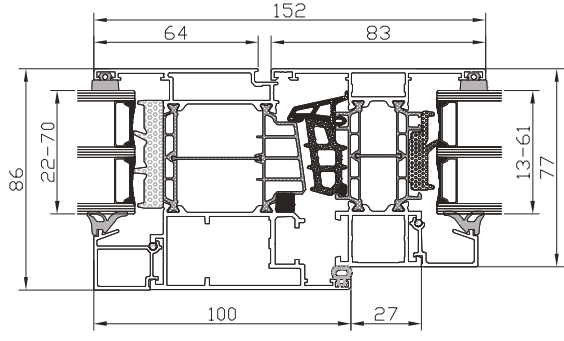

DA-77 SW.04/PP.02

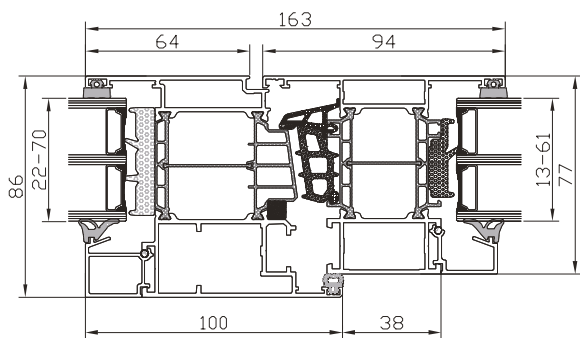

DA-77 SW.04/PP.03

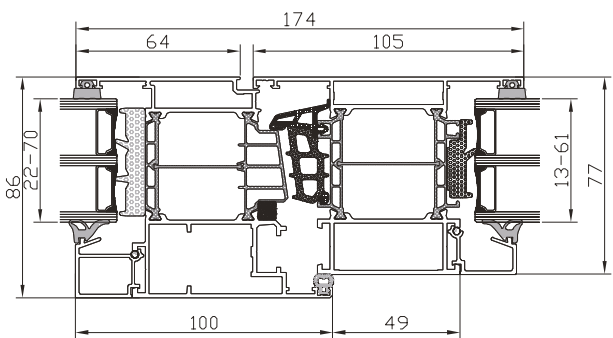

DA-77 SW.04/PP.04

## A - A

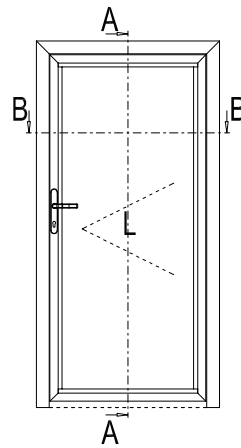
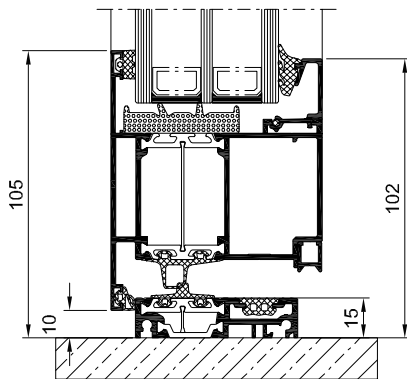
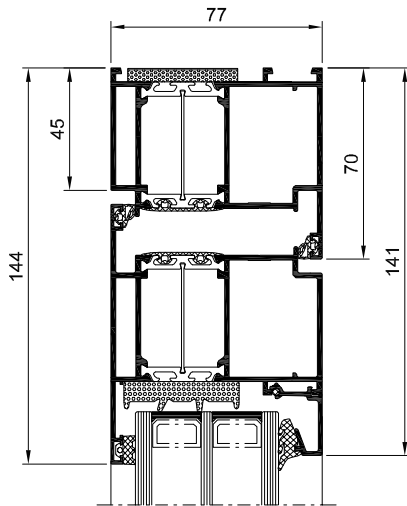

## B - B

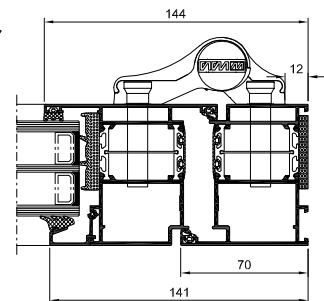
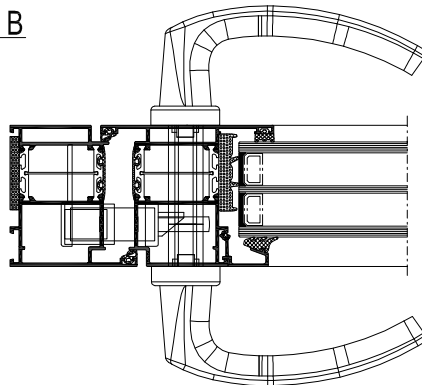

DA-77

1-sash door

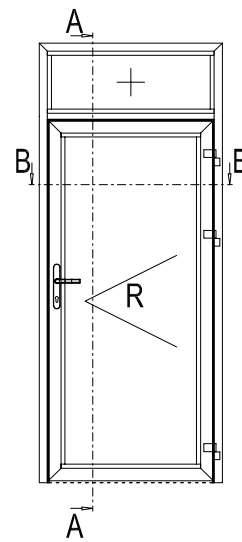
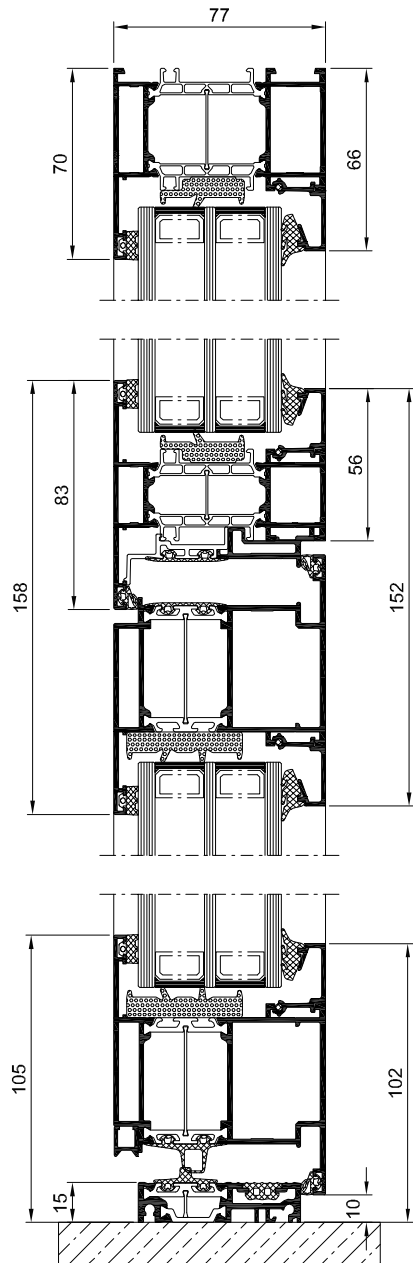

**B - B**

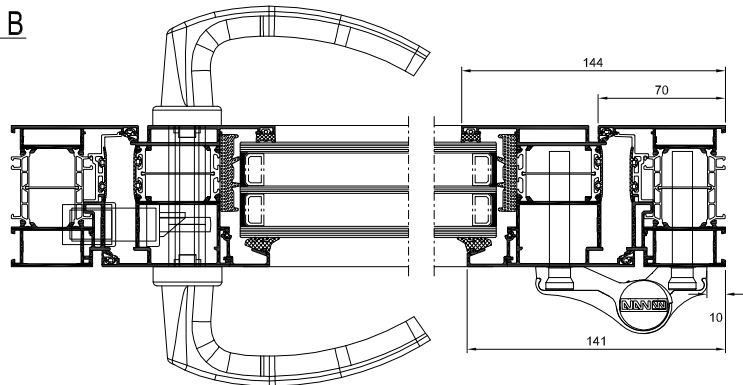

DA-77  
1-sash door with a transom

A - A

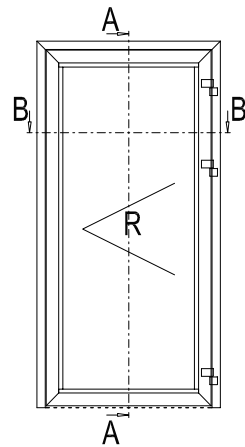
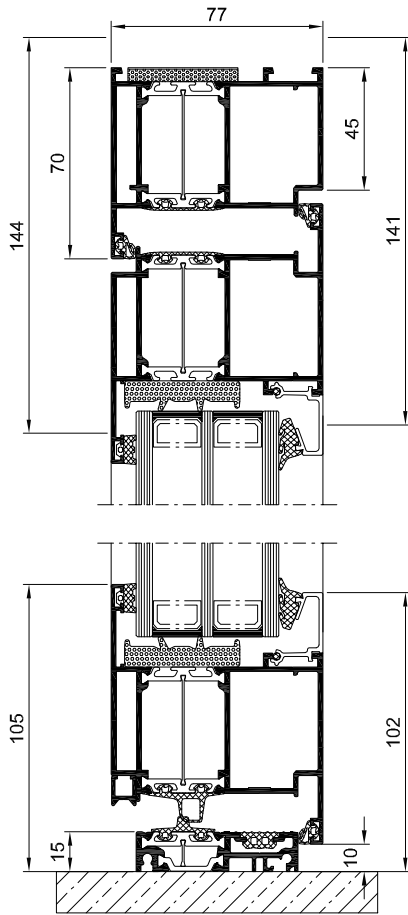

B - B

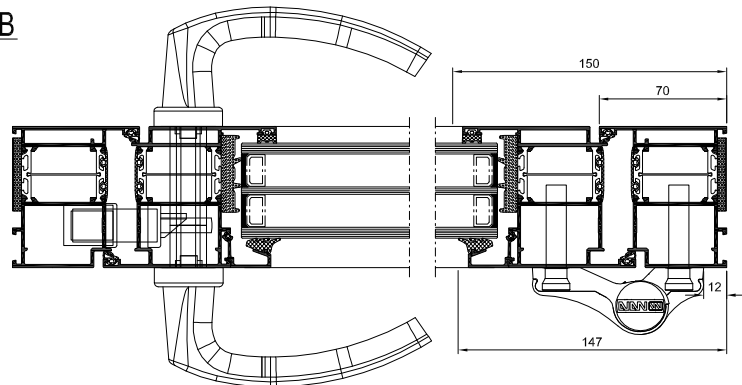

DA-77

1-sash door

A - A

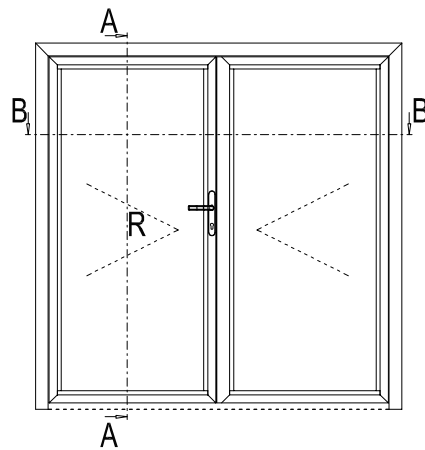
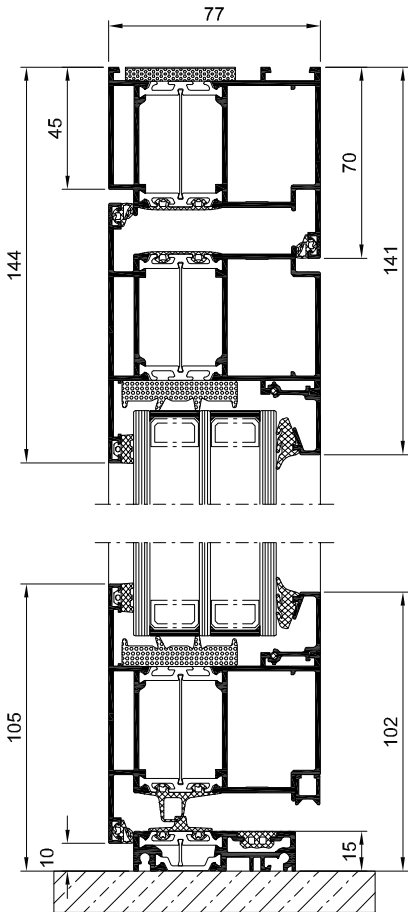

B - B

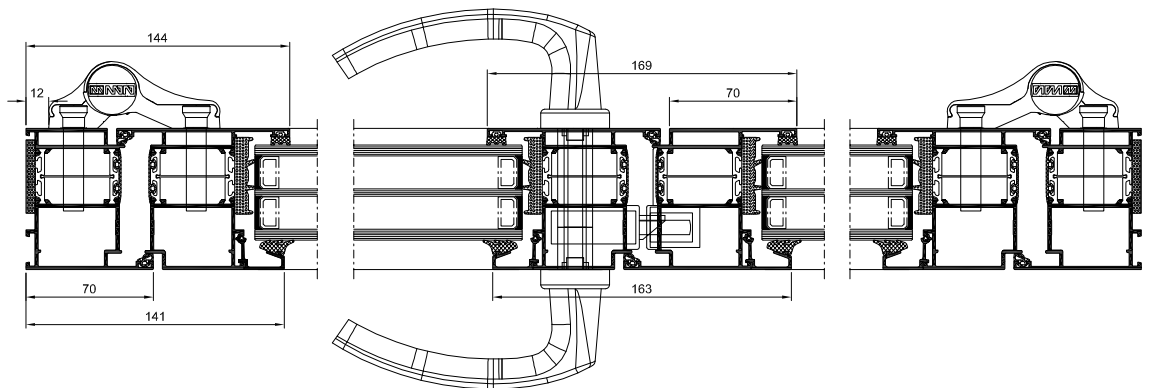

DA-77  
1-sash door with an opening vertical fixed window

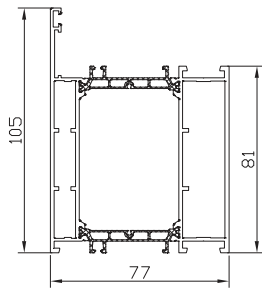

DA-77  
Frame FW.04

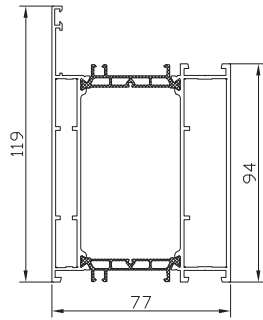

DA-77  
Frame FW.05

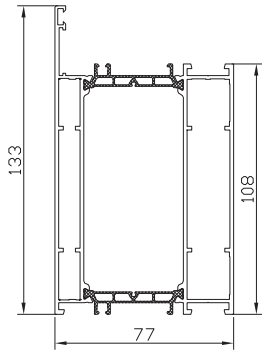

DA-77  
Frame FW.06

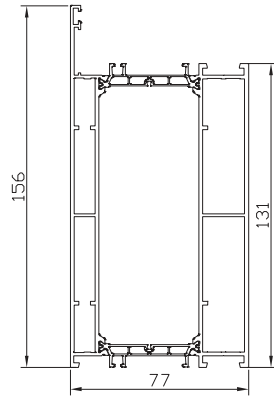

DA-77  
Frame FW.07

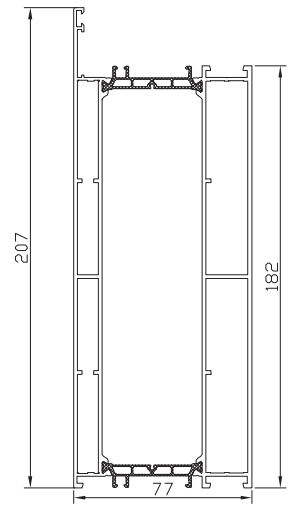

DA-77  
Frame FW.08

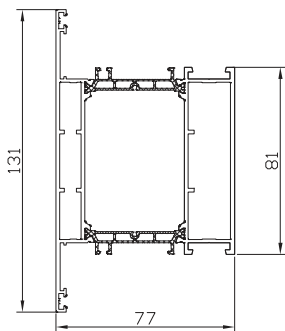

DA-77  
Fixed mullion PP.05

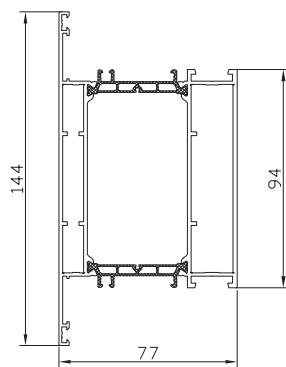

DA-77  
Fixed mullion PP.06

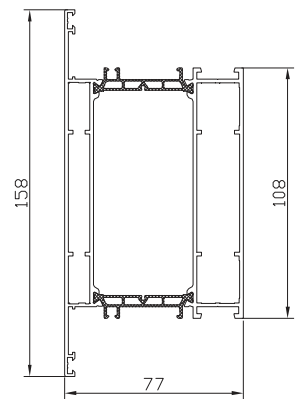

DA-77  
Fixed mullion PP.07

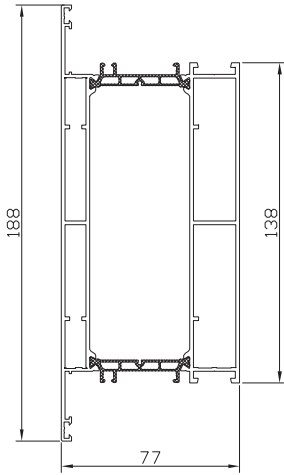

DA-77  
Fixed mullion PP.08

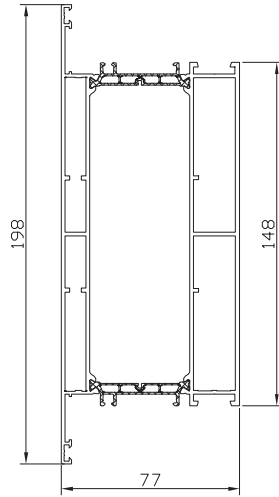

DA-77  
Fixed mullion PP.09

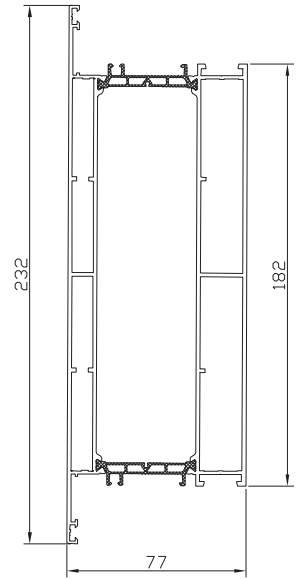

DA-77  
Fixed mullion PP.10

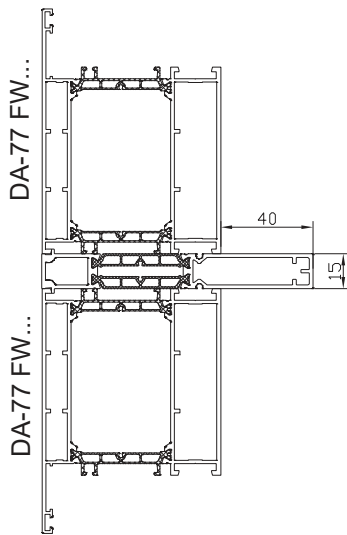

DA-77  
Expansion Joint FW...

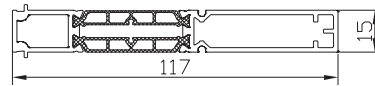

DA-77  
Expansion Joint CP.01

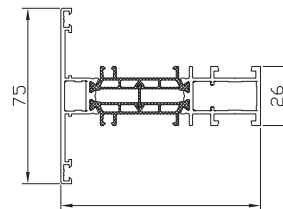

DA-77  
Crossbar in the frame  
SWP.01

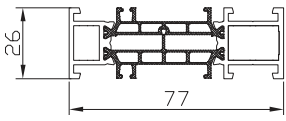

DA-77  
Expander SP.01

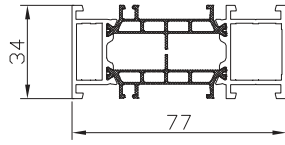

DA-77  
Expander SP.02

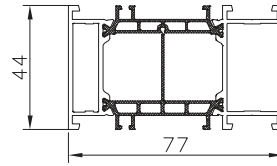

DA-77  
Expander SP.03

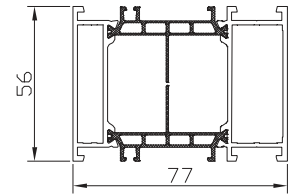

DA-77  
Expander SP.04

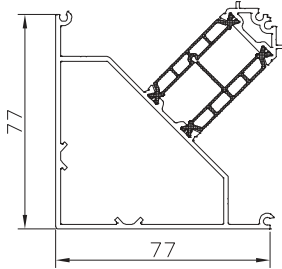

DA-77  
Corner joint 90° CP.02

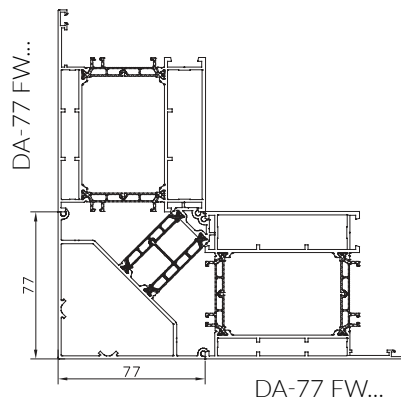

DA-77  
Corner joint 90° FW...

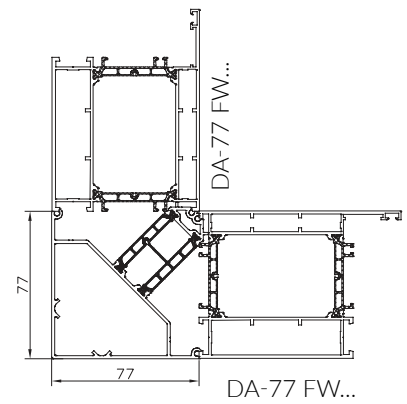

DA-77  
Corner joint 90° FW...

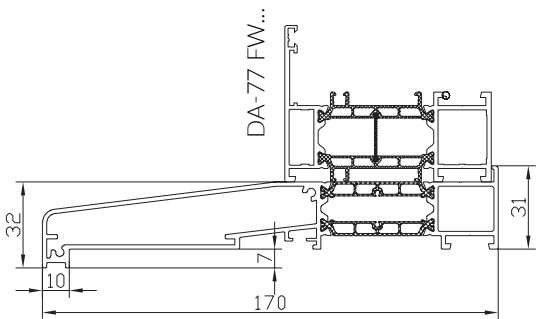

DA-77  
Sill profile  
(window sill) SM.01

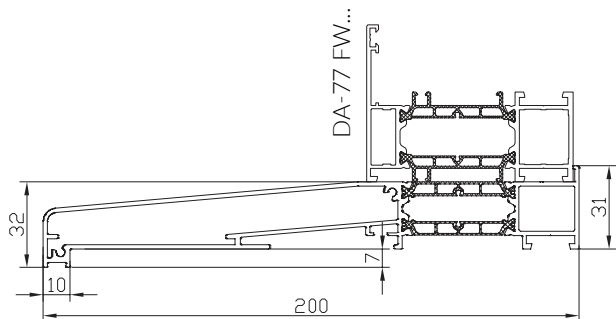

DA-77  
Sill profile  
(window sill) SM.02



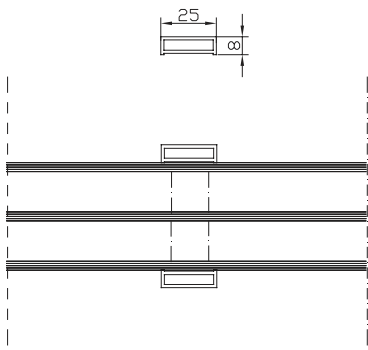

DA-77  
Glued-on muntin bars +  
DUPLEX: inter-pane muntin  
bars SWP.02

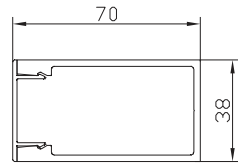

DA-77  
Tube reinforcement RP.01

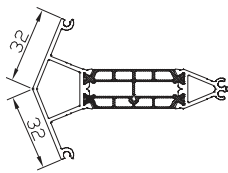
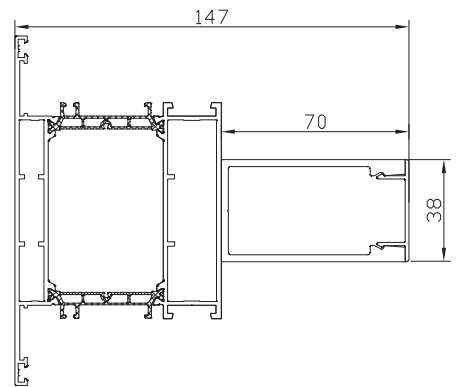

DA-77  
Corner joint CP.03

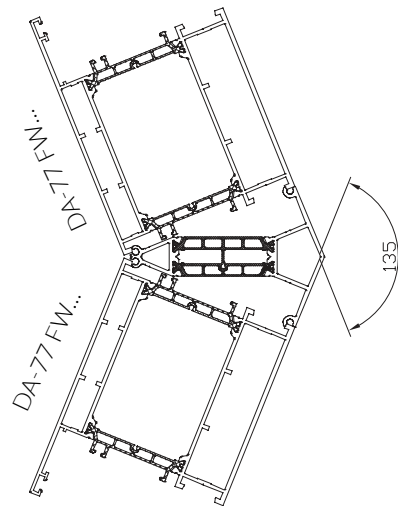

DA-77  
Corner joint FW...

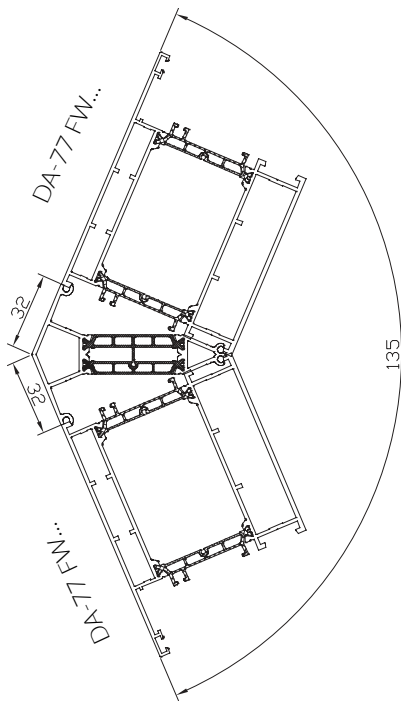

DA-77  
Corner joint FW...

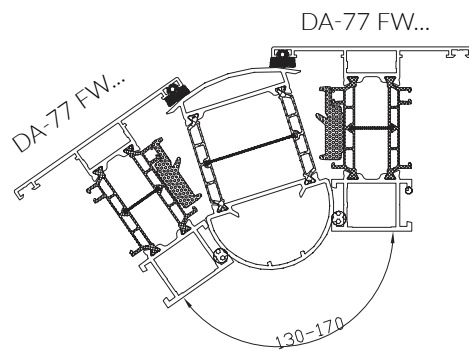

DA-77  
Corner joint PP...

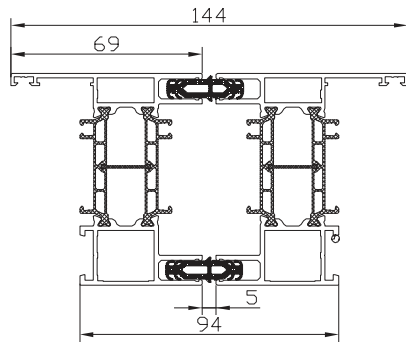

DA-77  
Expansion Joint EP.01

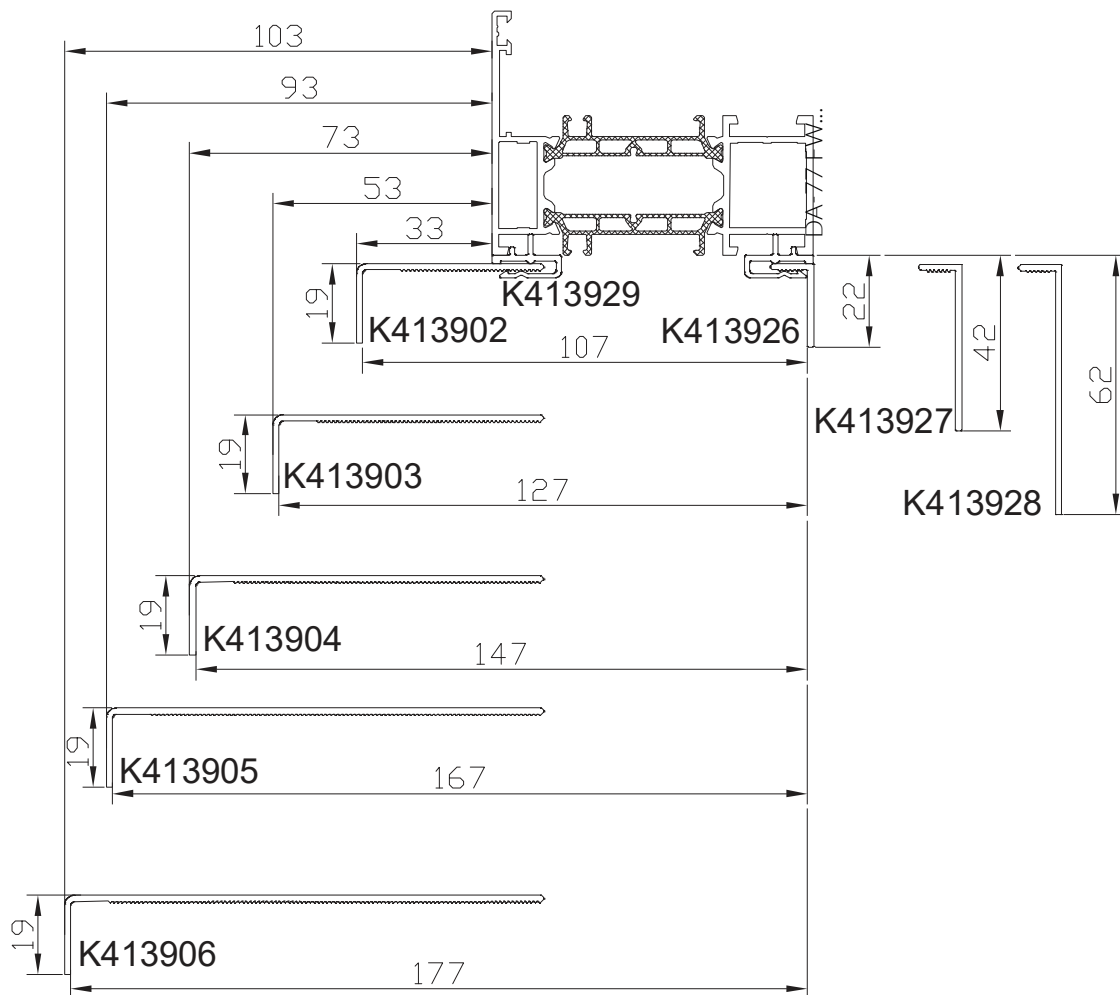

DA-77  
Covering profile for renovation

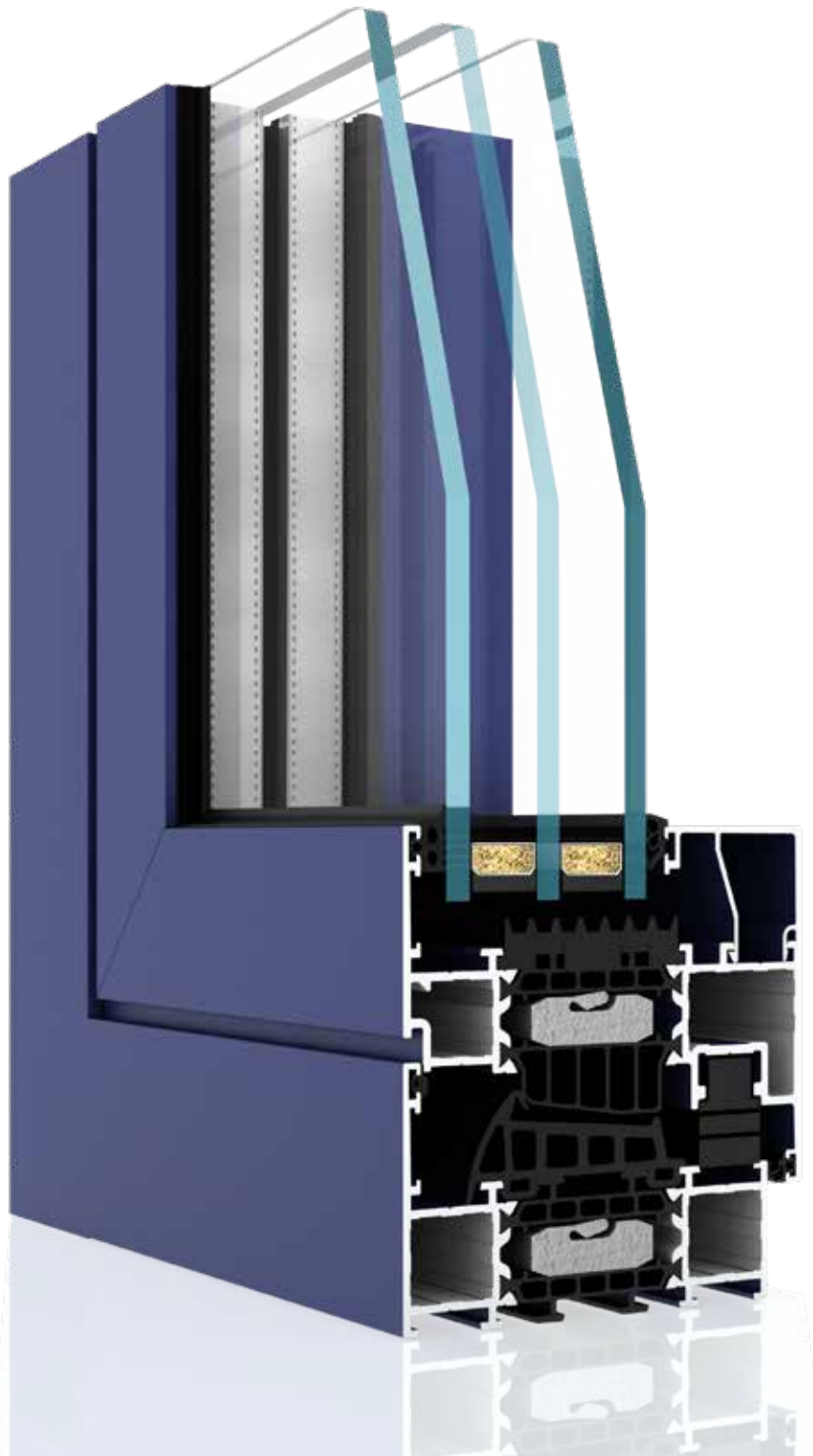

# DA-90 THERMO

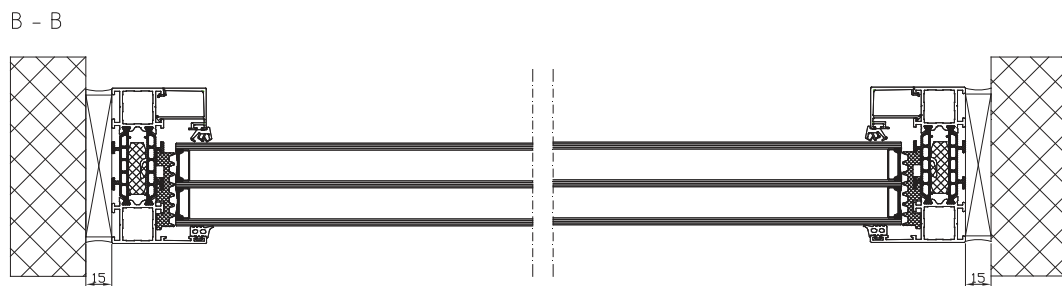
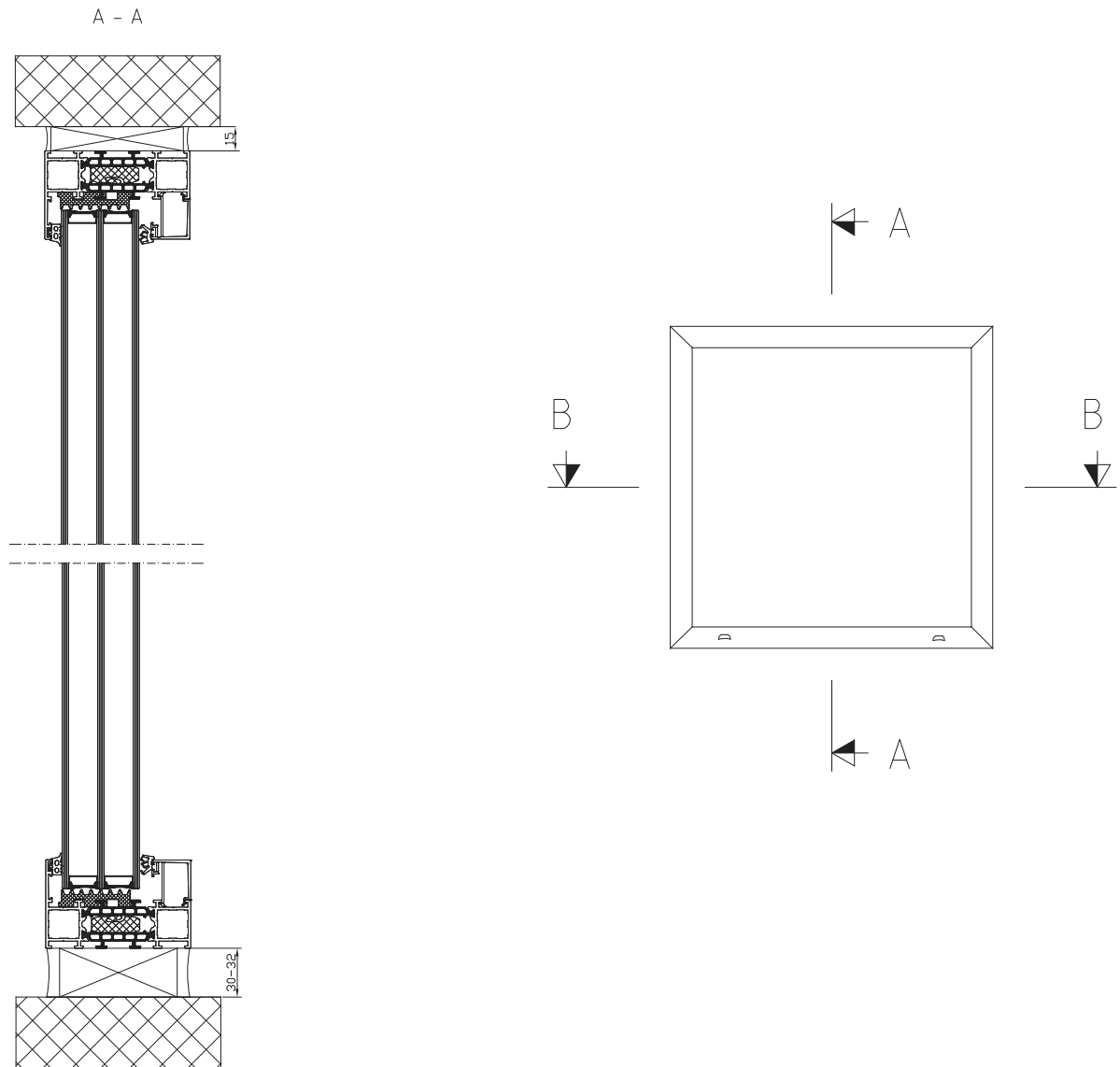

DA-90 thermo  
Fixed window

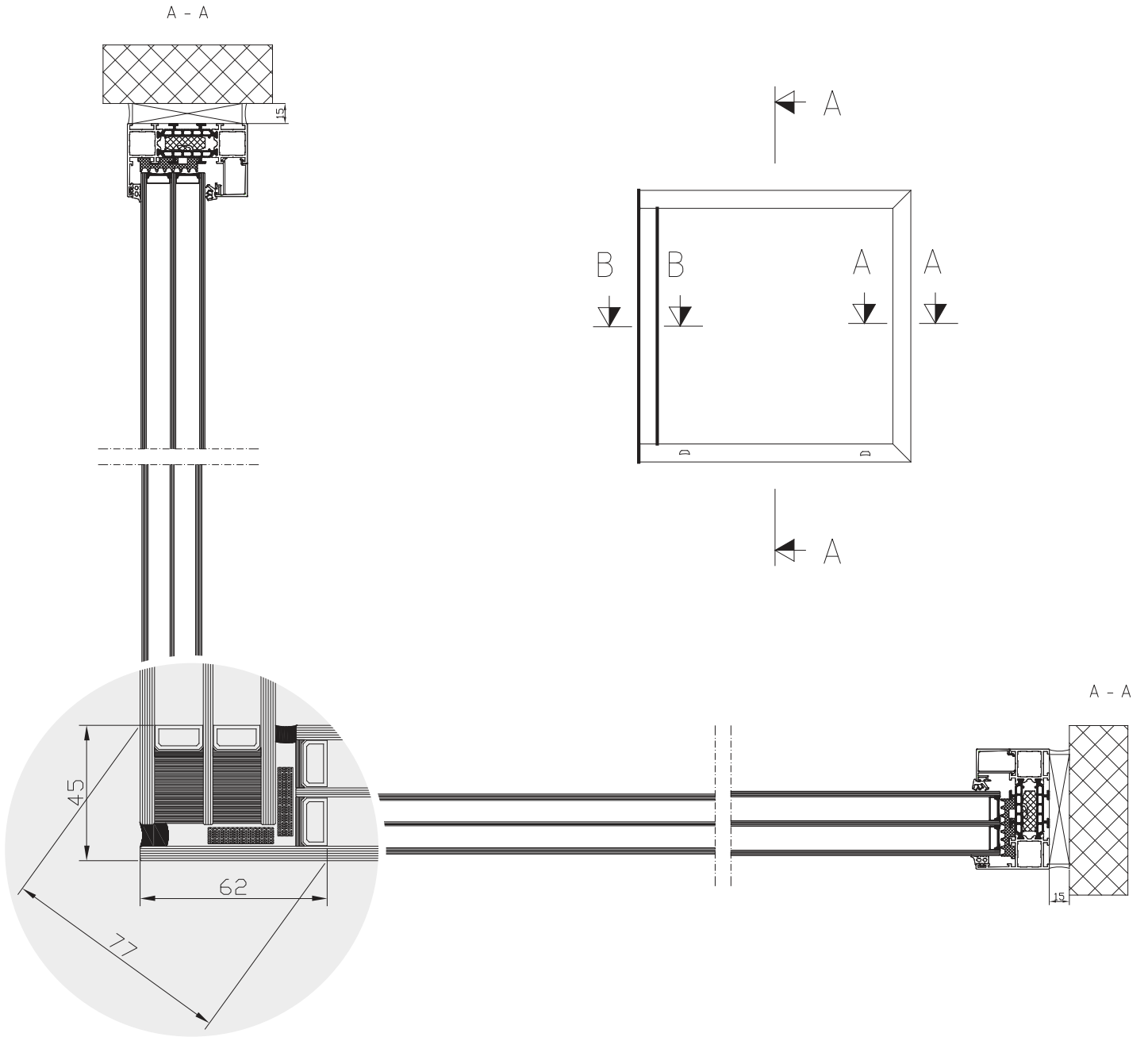

DA-90 thermo  
90 °

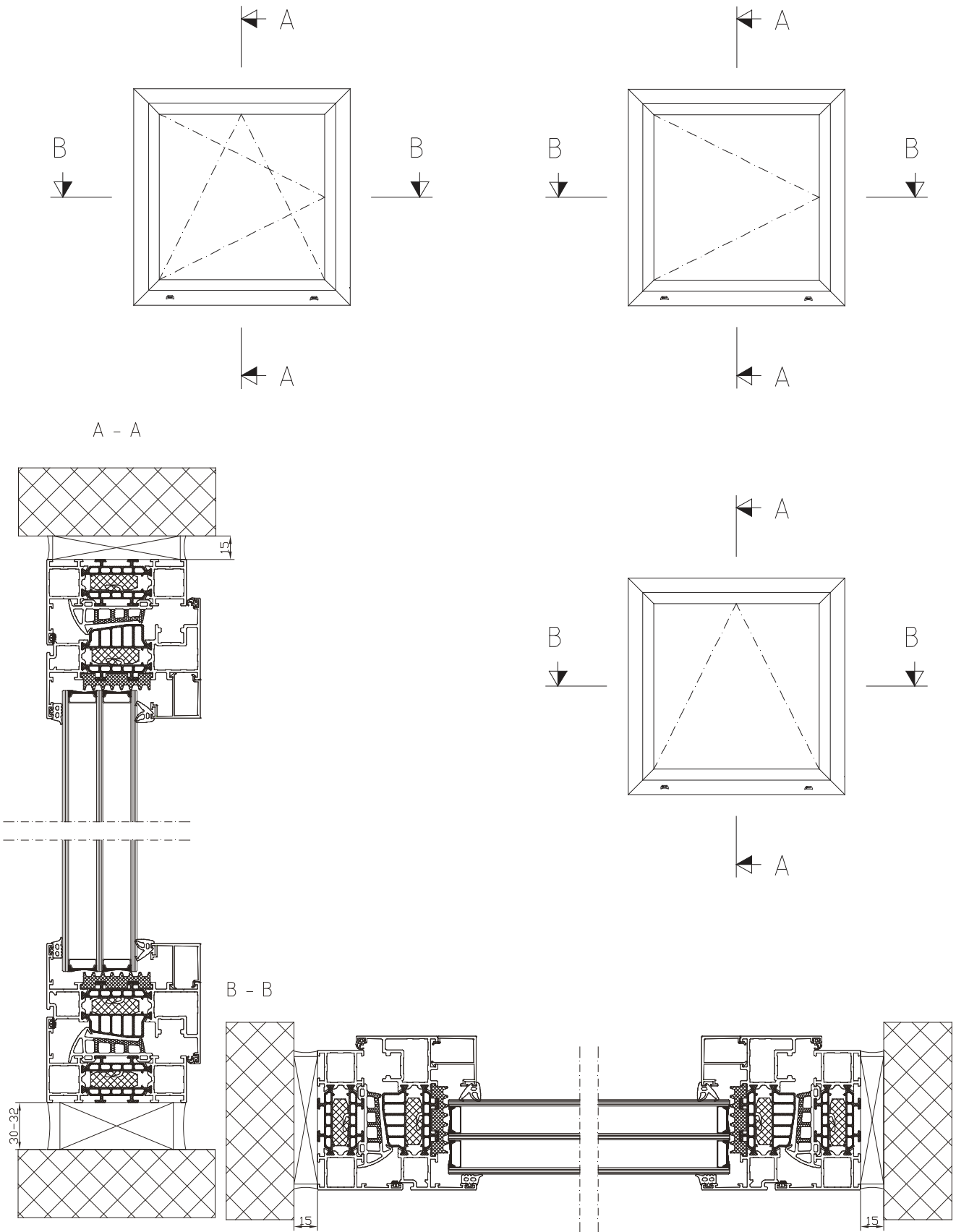

DA-90 thermo  
1-sash window

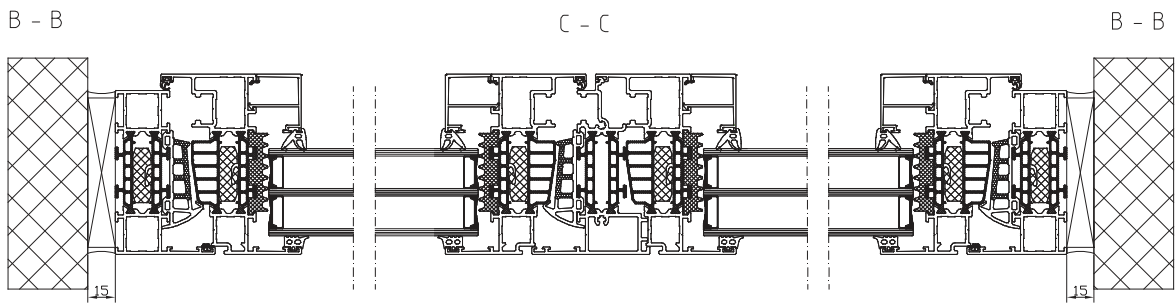
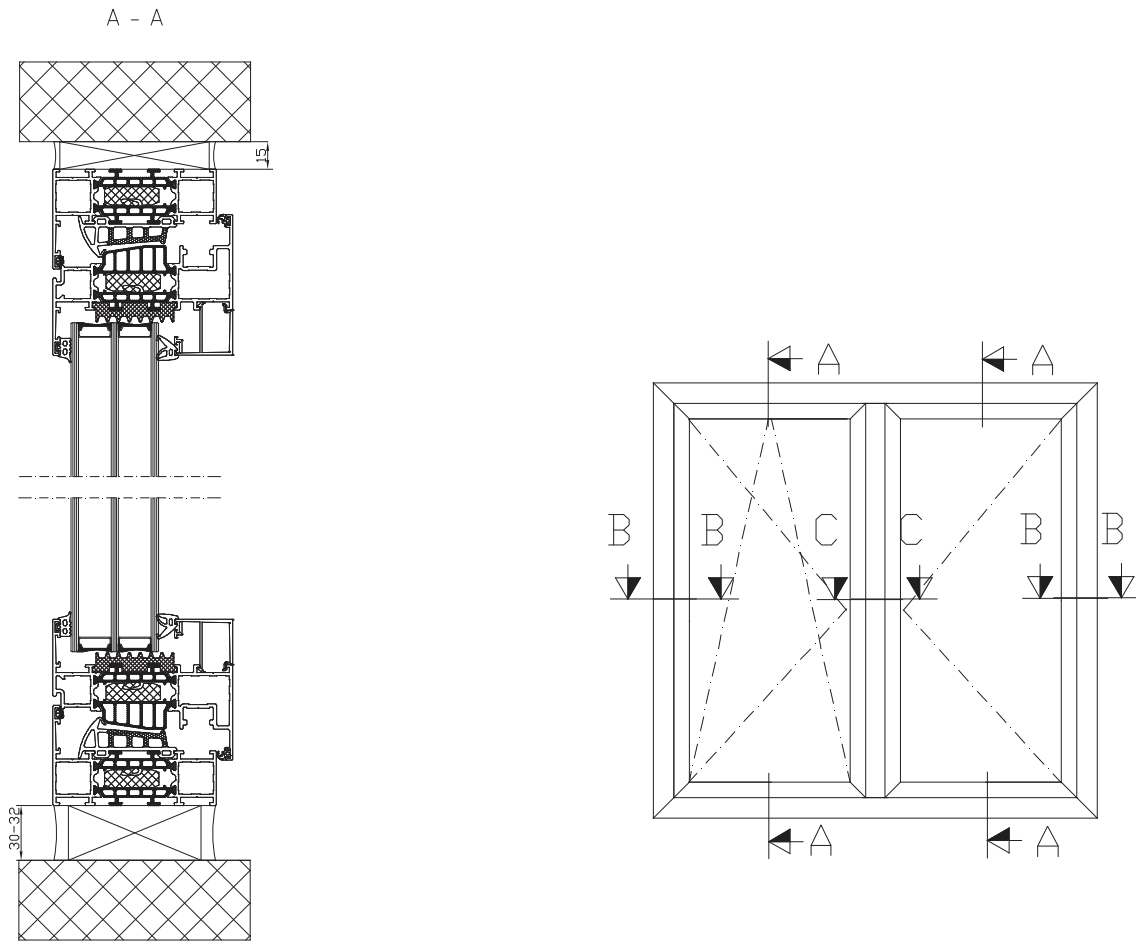

DA-90 thermo  
Window with a movable mullion

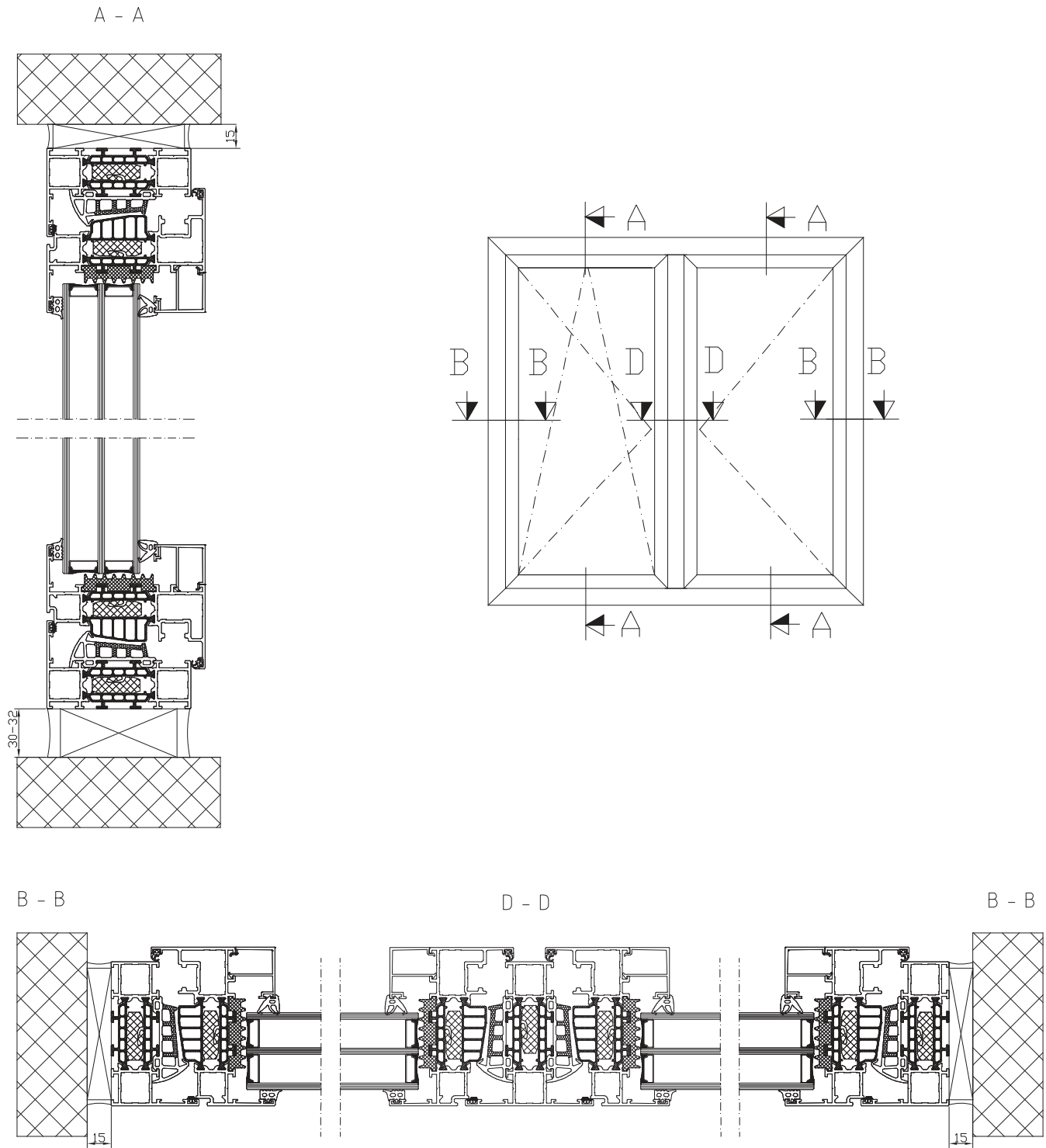

DA-90 thermo  
Window with a fixed mullion



A - A

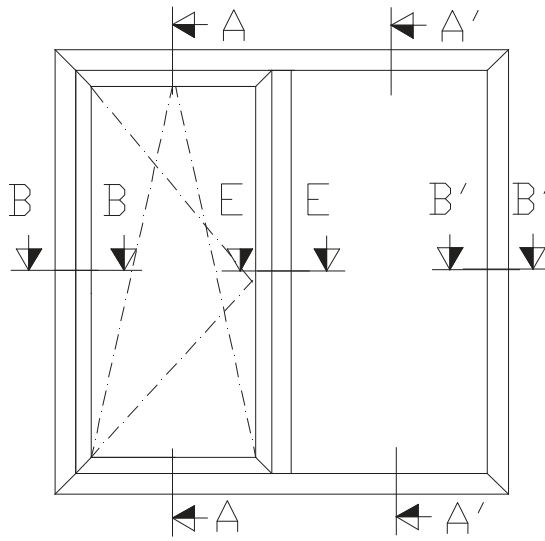
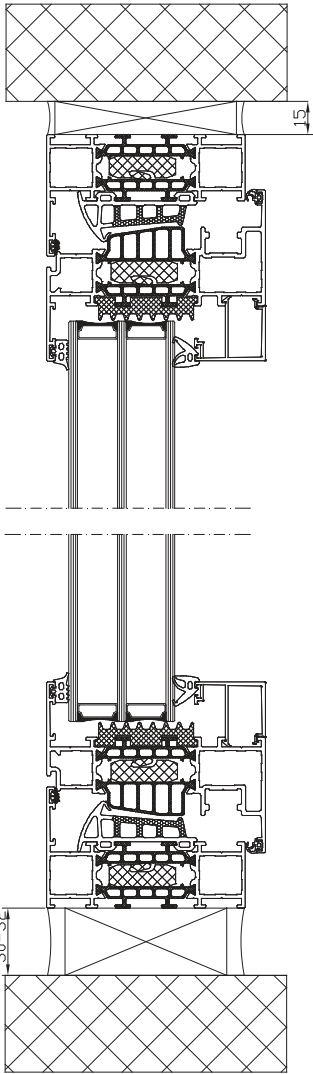

B - B

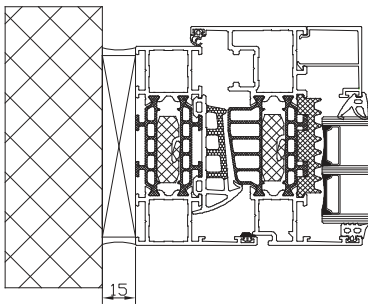

E - E

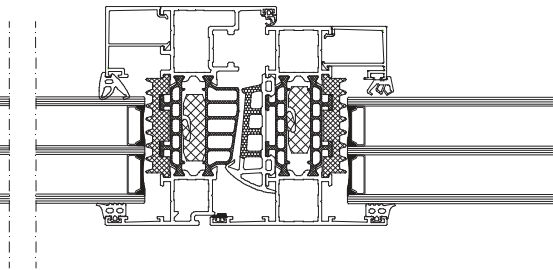

B' - B'

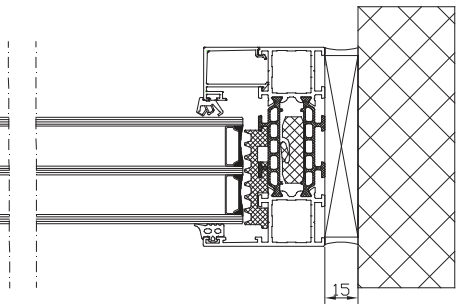

DA-90 thermo  
Tilt-and-turn window + fixed

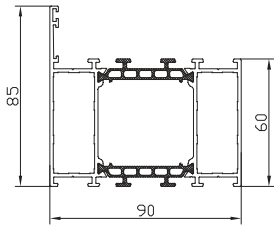

DA-90 thermo  
Frame DA-90Thermo FW.04

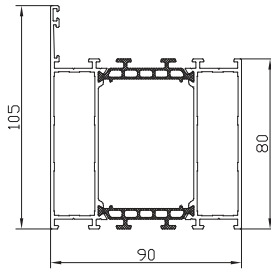

DA-90 thermo  
Frame DA-90Thermo FW.05

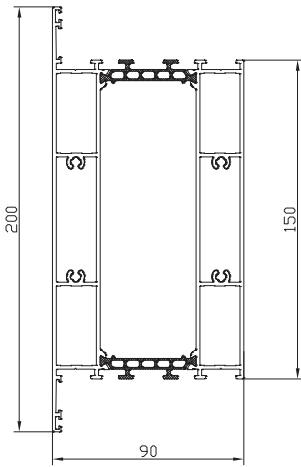

DA-90 thermo  
Fixed mullion DA-90Thermo PP.05

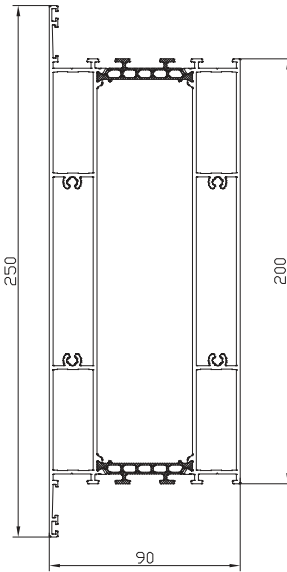

DA-90 thermo  
Fixed mullion DA-90Thermo PP.06

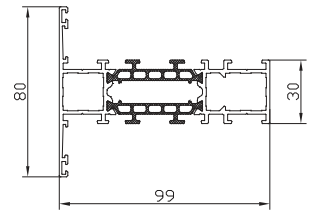

DA-90 thermo  
Mullion in the sash DA-90Thermo SWP.01

DA-90 THERMO FW... DA-90 THERMO FW...

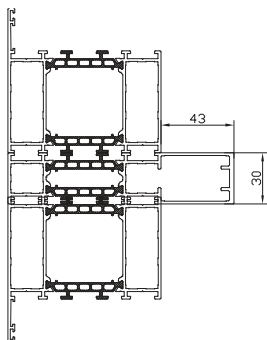

DA-90 thermo  
Expansion Joint DA-90Thermo FW...

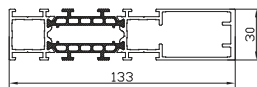

DA-90 thermo  
Expansion Joint DA-90Thermo CP.01

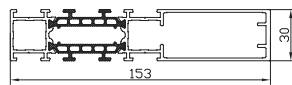

DA-90 thermo  
Expansion Joint DA-90Thermo CP.02

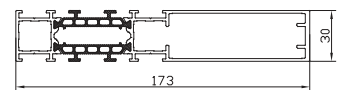

DA-90 thermo  
Expansion Joint DA-90Thermo CP.03

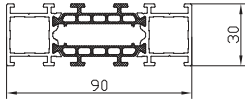

DA-90 thermo  
Expander DA-90Thermo SP.01

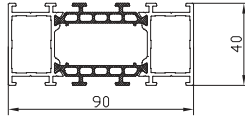

DA-90 thermo  
Expander DA-90Thermo SP.02

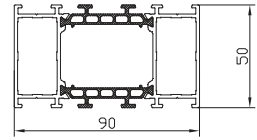

DA-90 thermo  
Expander DA-90Thermo SP.03

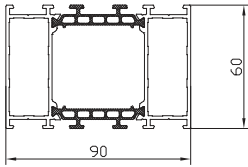

DA-90 thermo  
Expander DA-90Thermo SP.04

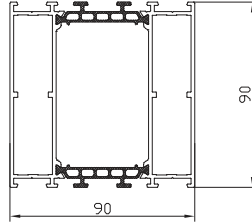

DA-90 thermo  
Expander DA-90Thermo SP.06

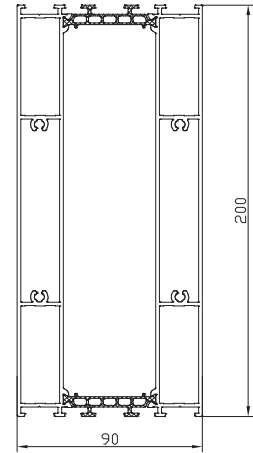

DA-90 thermo  
Expander DA-90Thermo SP.08

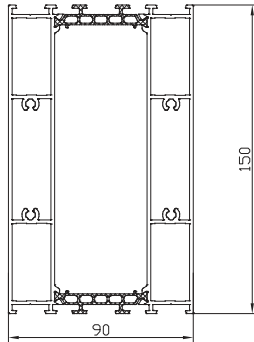

DA-90 thermo  
Expander DA-90Thermo SP.07

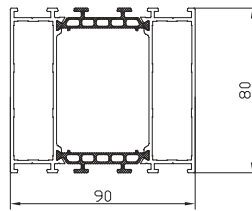

DA-90 thermo  
Expander DA-90Thermo SP.05

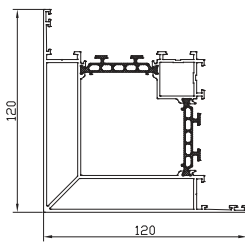

DA-90 thermo  
Corner joint 90° DA-90Thermo CP.05

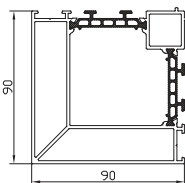

DA-90 thermo  
Corner joint 90° DA-90Thermo CP.04

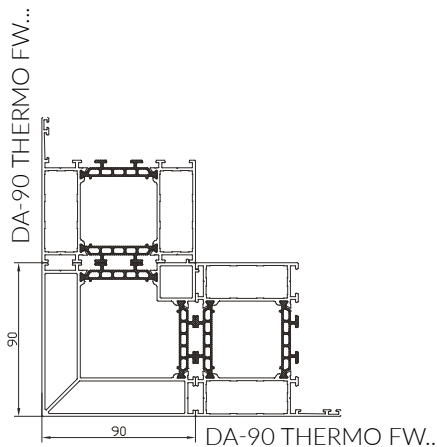

DA-90 thermo  
Corner joint 90° DA-90Thermo FW...

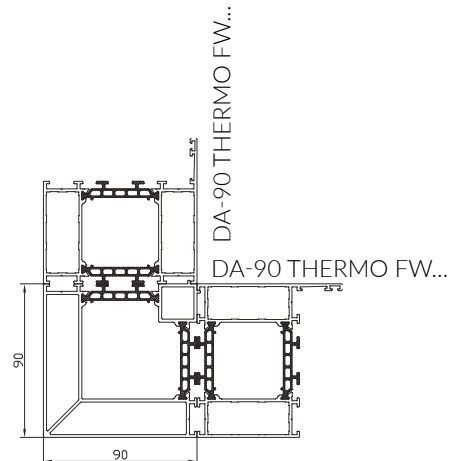

DA-90 thermo  
Corner joint 90° DA-90Thermo FW...

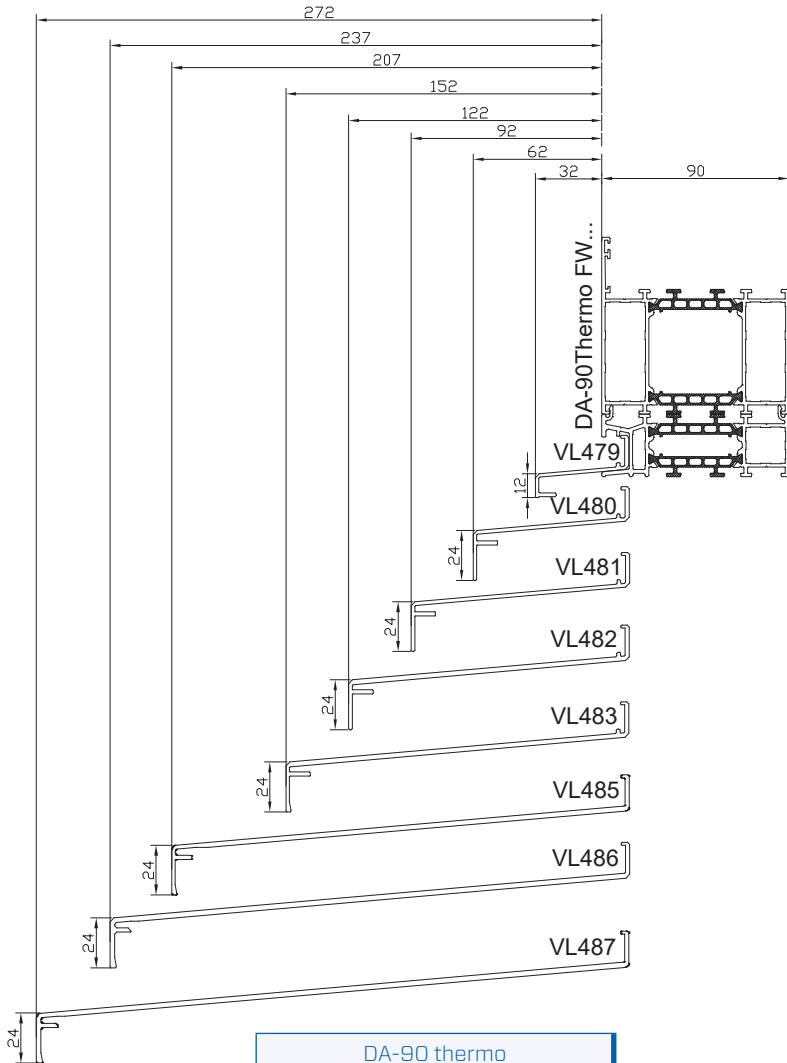

DA-90 thermo  
Sill profile DA-90Thermo FW...

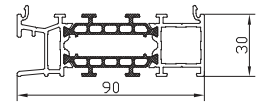

DA-90 thermo  
Sill profile DA-90Thermo SM.01

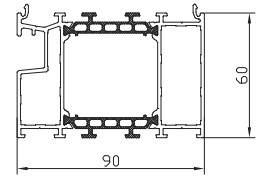

DA-90 thermo  
Sill profile DA-90Thermo SM.02

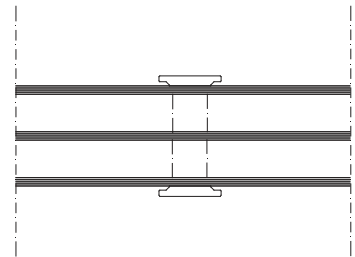

DA-90 thermo  
External muntin bar DA-90Thermo SWP.02

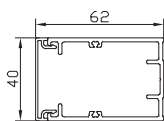

DA-90 thermo  
Tube reinforcement  
DA-90Thermo RP.01

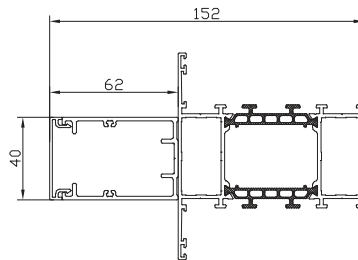

DA-90 thermo  
Tube reinforcement  
DA-90Thermo RP.01/O

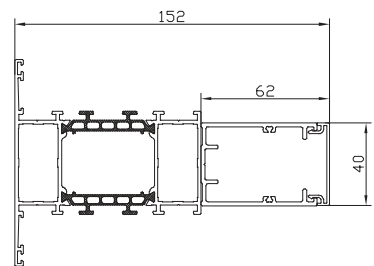

DA-90 thermo  
Tube reinforcement  
DA-90Thermo RP.01/I

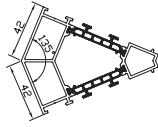

DA-90 thermo  
Connector 135° DA-90Thermo  
CP.06

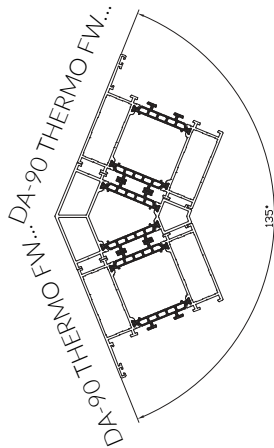

DA-90 thermo  
Connector 135° DA-90Thermo  
FW...

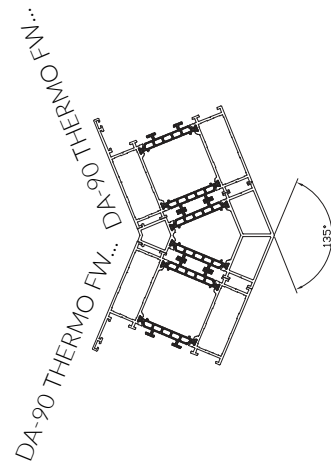

DA-90 thermo  
Connector 135° DA-90Thermo  
FW...

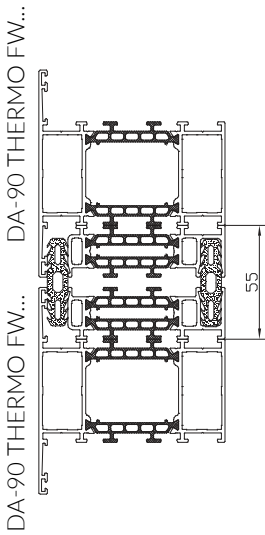

DA-90 thermo  
Expansion profile  
DA-90Thermo PP...

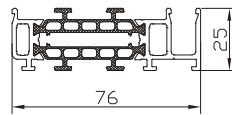

DA-90 thermo  
Expansion profile  
DA-90Thermo EP.01

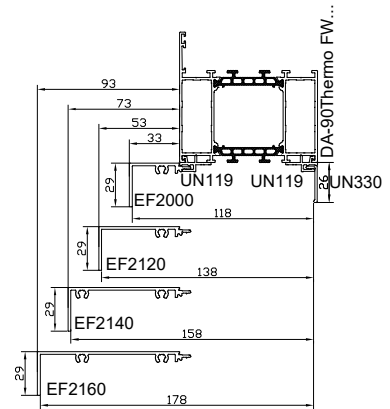

DA-90 thermo  
Renovation profile  
DA-90Thermo FW...

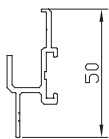

DA-90 thermo  
Finishing profile  
DA-90Thermo BD.01

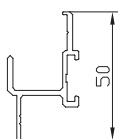

DA-90 thermo  
Finishing profile  
DA-90Thermo BD.02

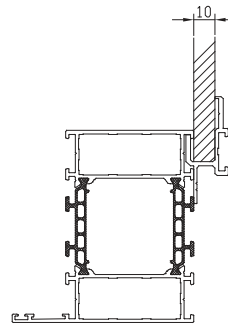

DA-90 thermo  
Finishing profile  
DA-90Thermo BD.01

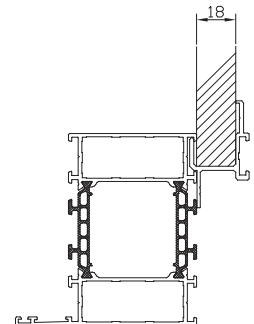

DA-90 thermo  
Finishing profile  
DA-90Thermo BD.02



## DA-77 HST

Lift and slide  
Frame depth - 174mm

A - A

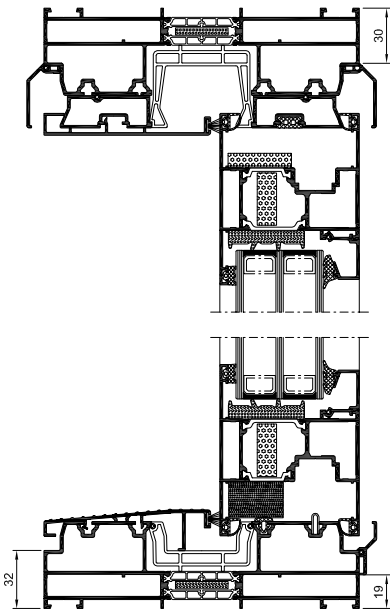

C - C

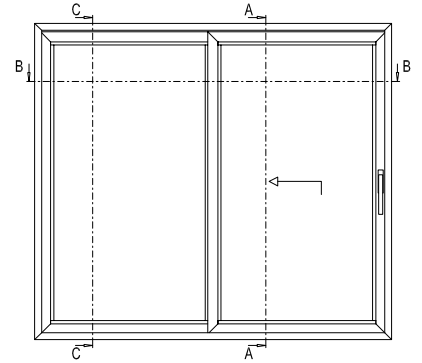
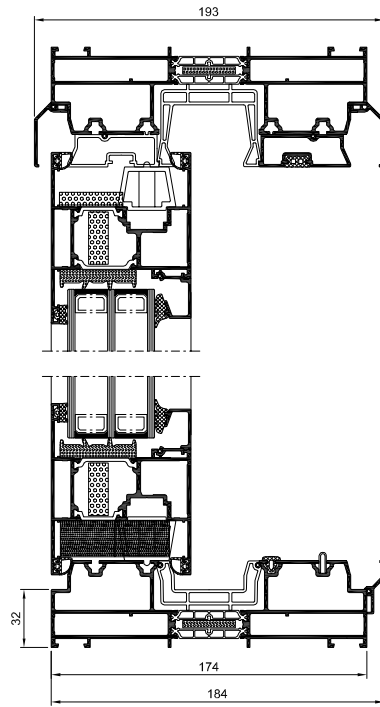

DA-77 HST

Lift and slide  
1 sliding sash

B - B

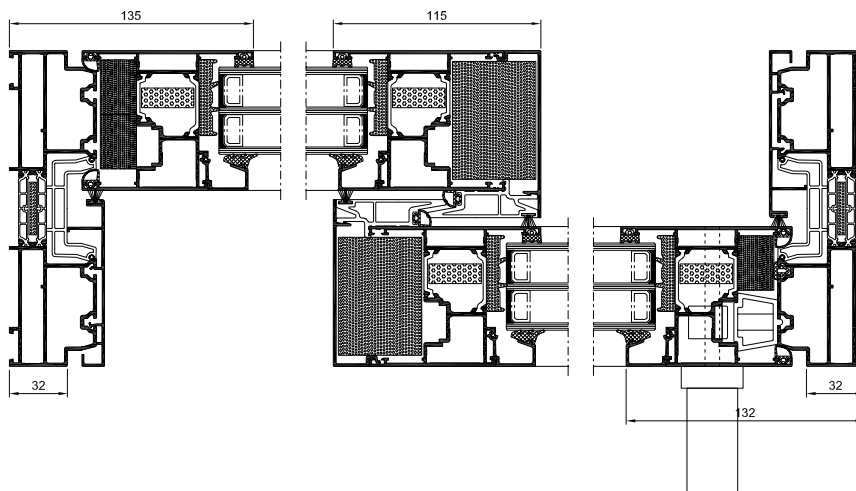

A - A

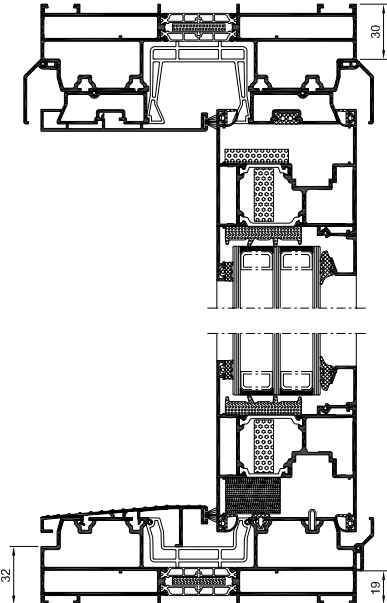

C - C

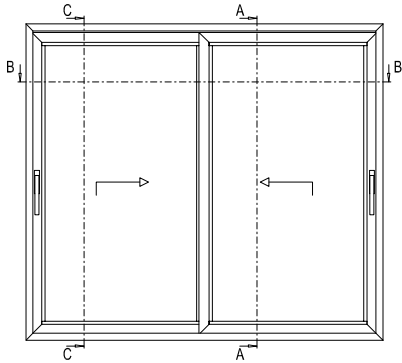
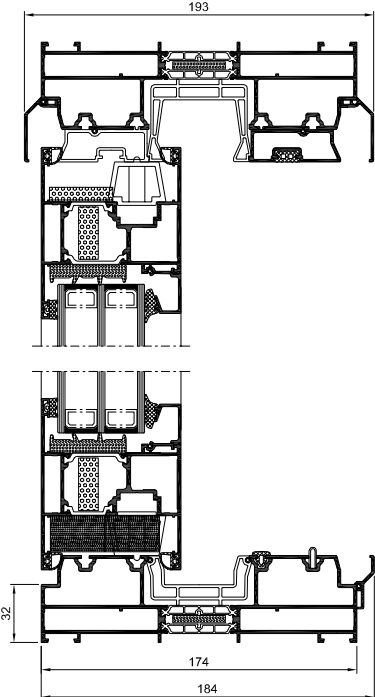

DA-77 HST  
Lift and slide  
2 sliding sashes

B - B

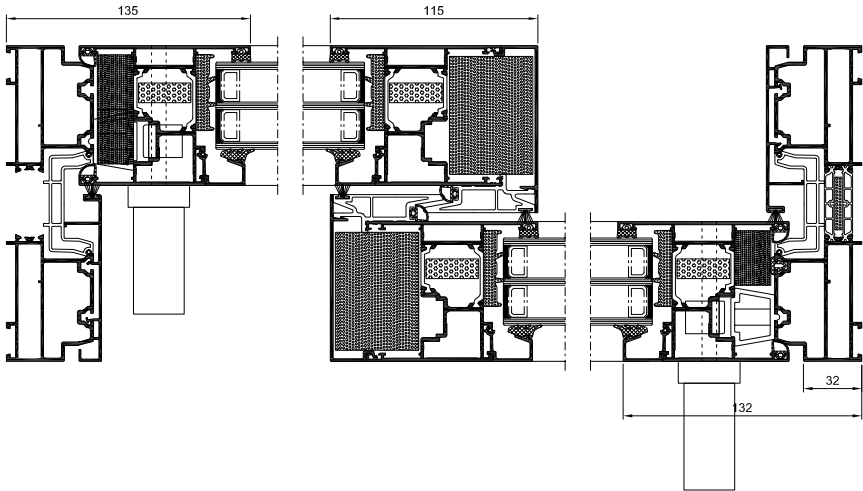



A - A

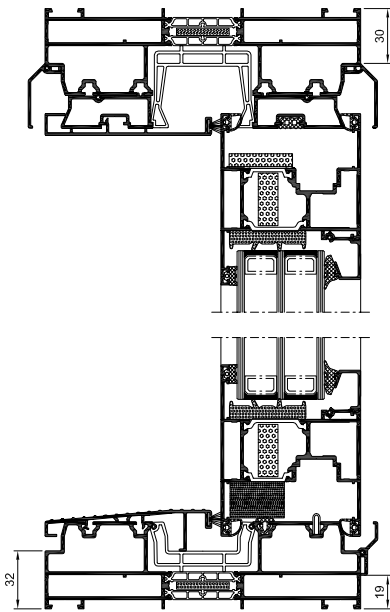

C - C

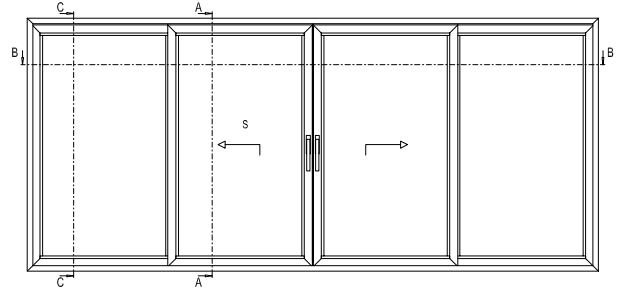
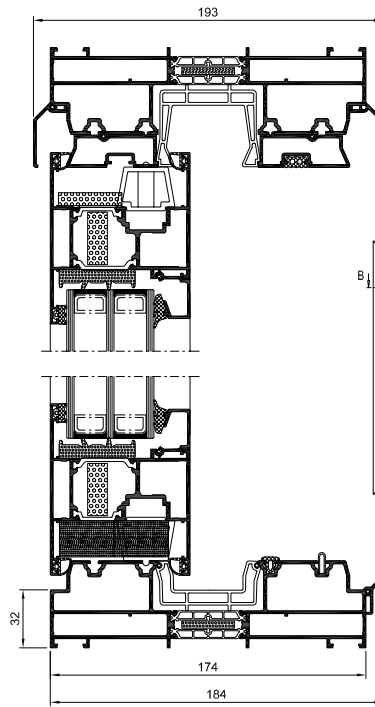

DA-77 HST

Lift and slide door with 4 sashes  
of which 2 are sliding

B - B

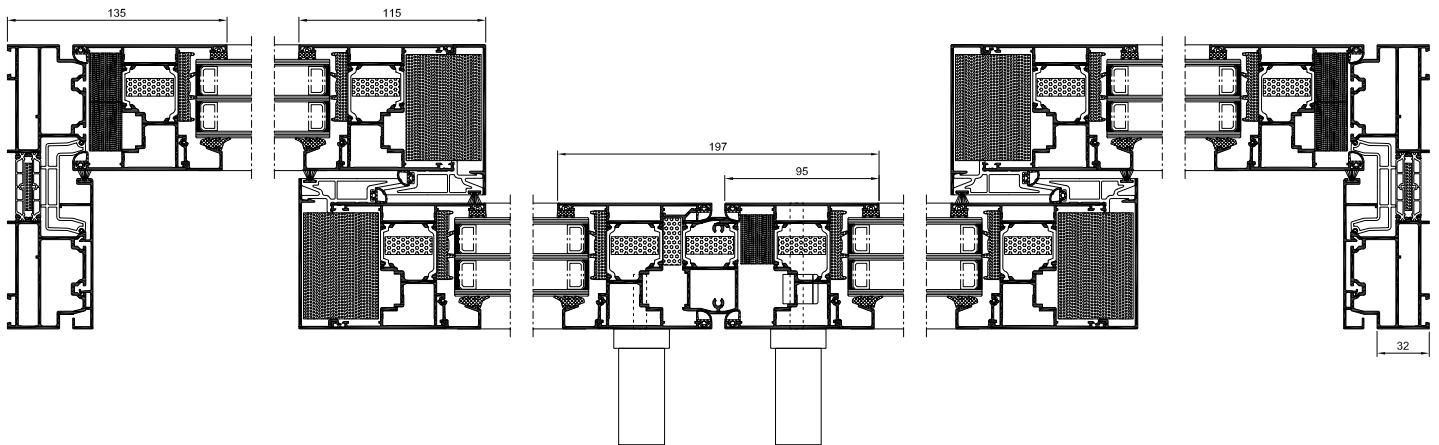

A - A

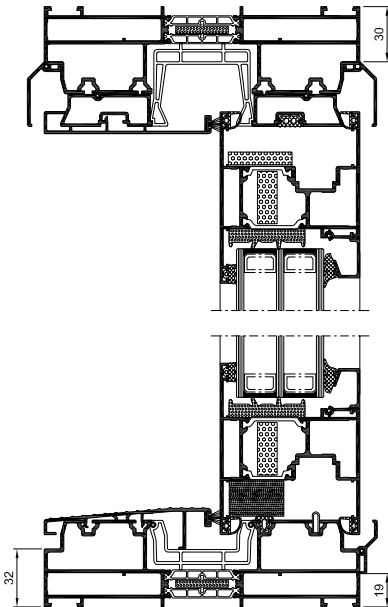

C - C

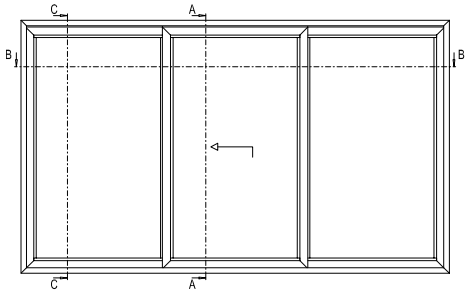
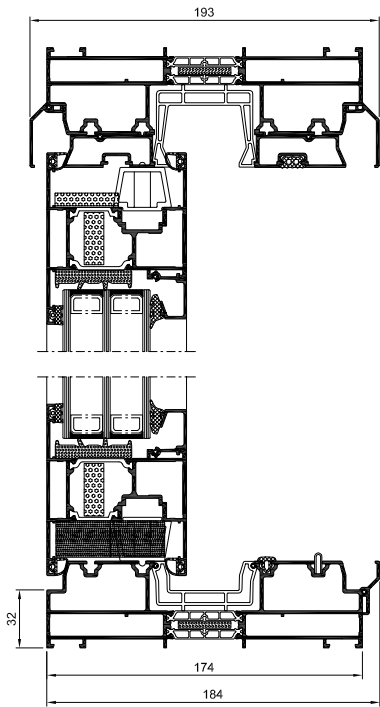

DA-77 HST  
Lift and slide door with 3 sashes  
of which 1 is sliding

B - B

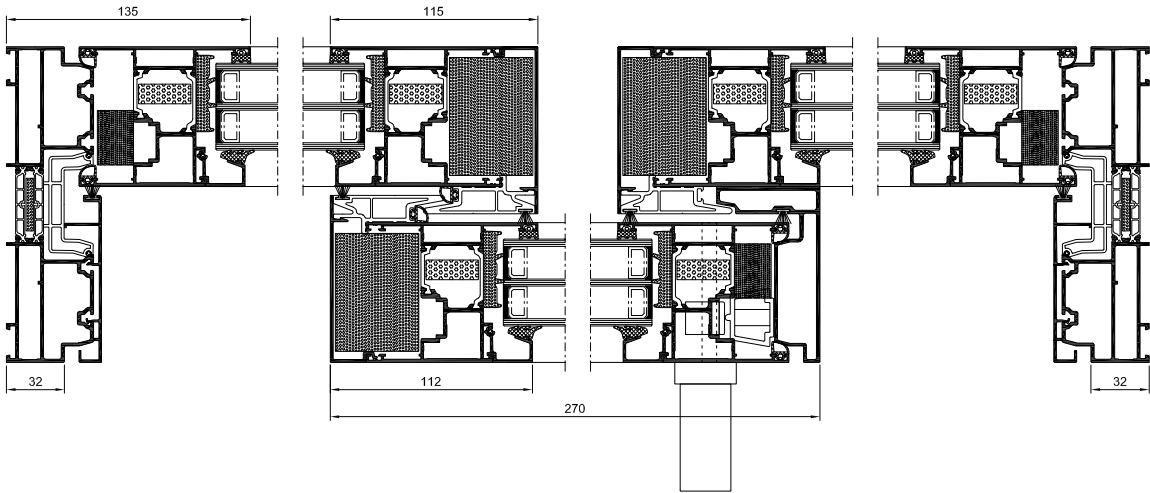



## DA-40 ST

Sliding doors with 2 or 3 rails, wall mounted  
Frame with top-mounted roller shutters

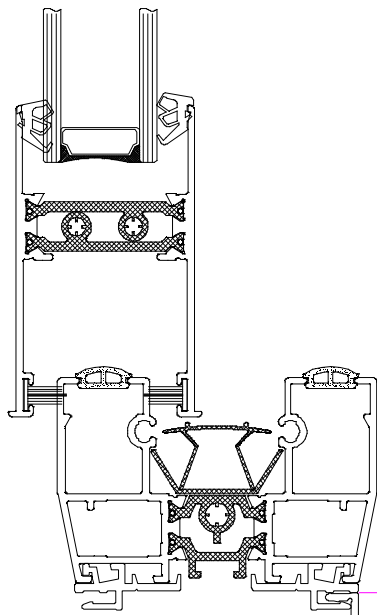

DA-40 ST  
Standard frame MDS010

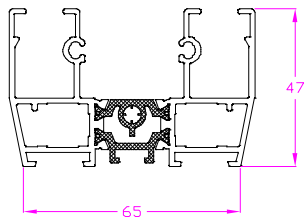
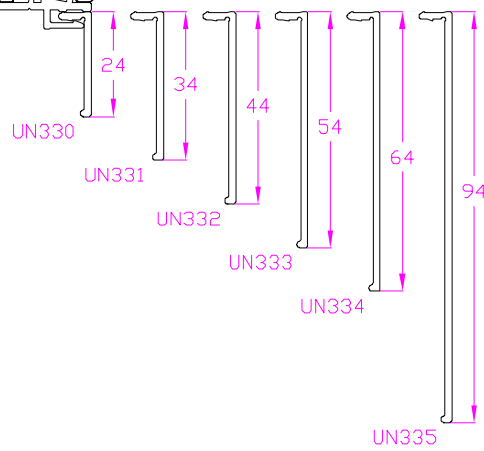

DA-40 ST  
Standard frame MDS010 - add UNI119 clips to link the renovation sashes

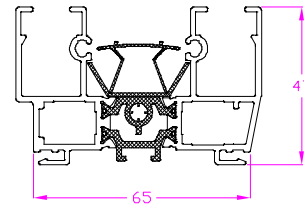

DA-40 ST  
Frame with double grooves MDS010 - clip the exterior/interior finishing profiles

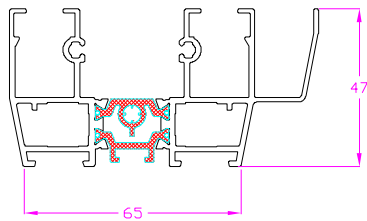

DA-40 ST  
Frame MDS010 - threshold depth 47mm

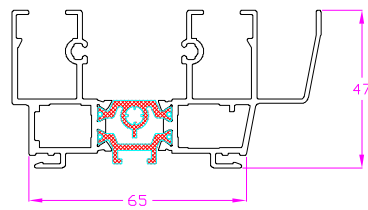

DA-40 ST  
Frame MDS010 - threshold depth 47mm double groove for linking exterior/interior finishing profiles

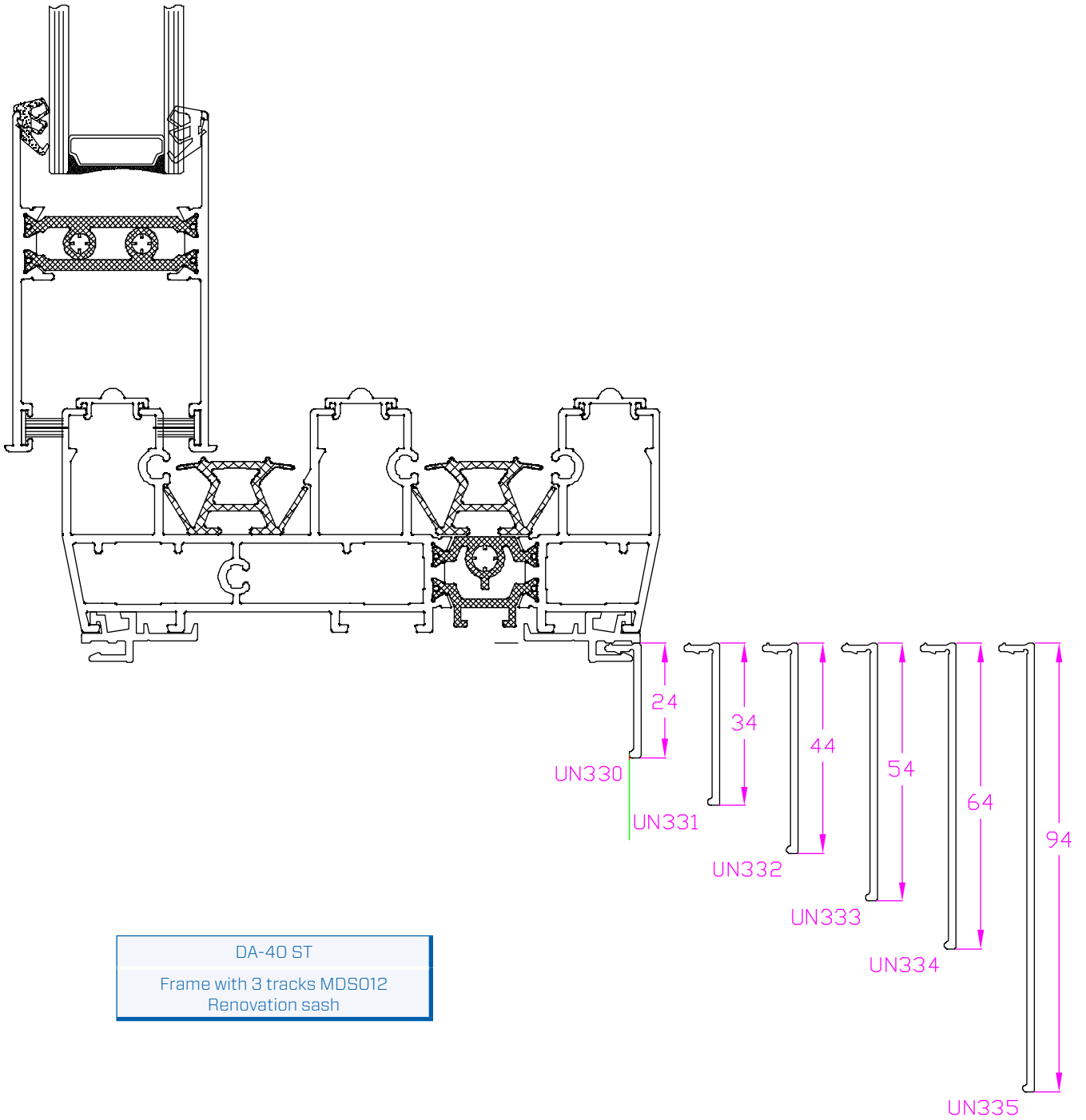



**DA-51 ST**

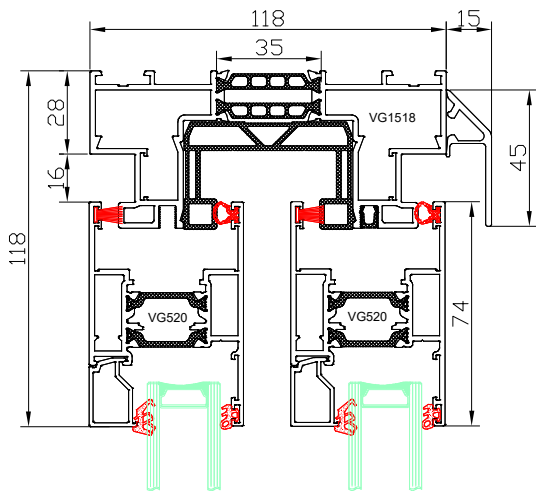

|                     |
|---------------------|
| DA-51 ST            |
| Frame with 2 tracks |
| Frame: VG1518       |
| Sash: VG520         |

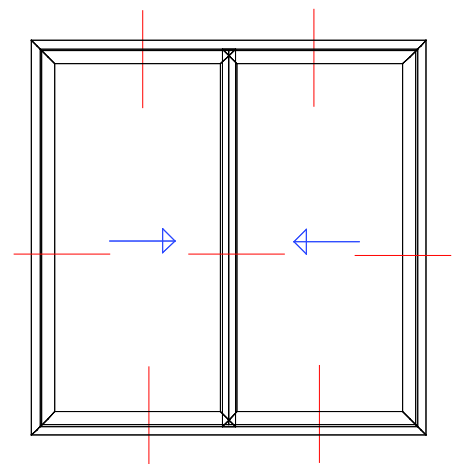
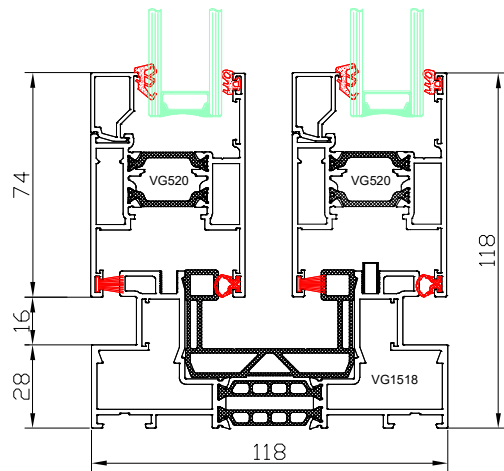

|                     |
|---------------------|
| DA-51 ST            |
| Frame with 2 tracks |
| Frame: VG1518       |
| Sash: VG520         |
| Post: 84 mm         |

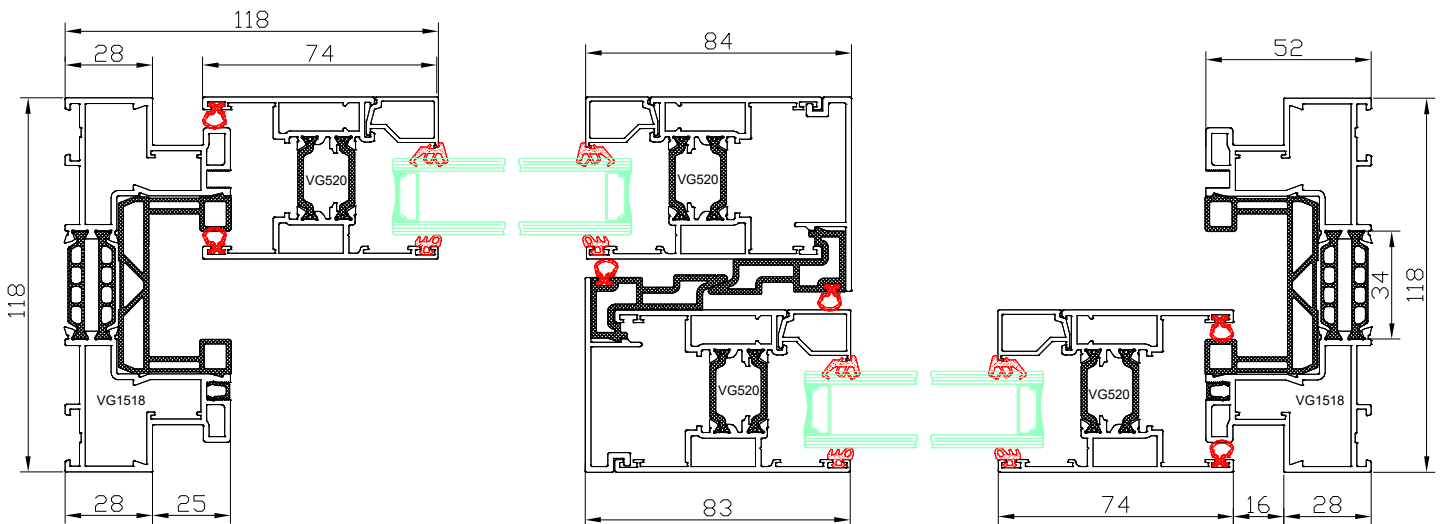

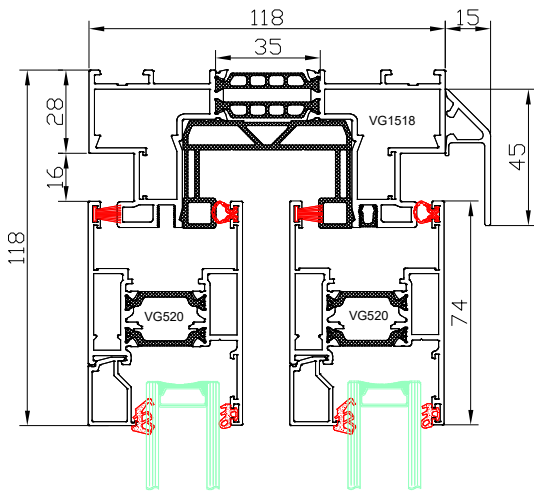

|                     |
|---------------------|
| DA-51 ST            |
| Frame with 2 tracks |
| Frame: VG1518       |
| Sash: VG520         |

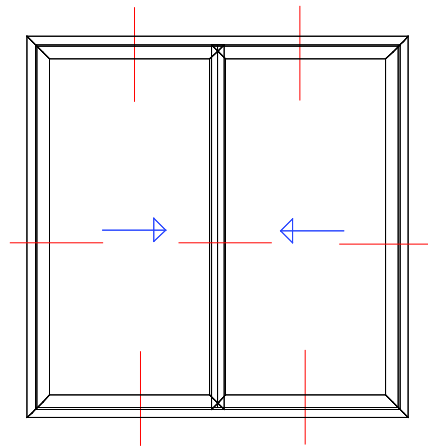
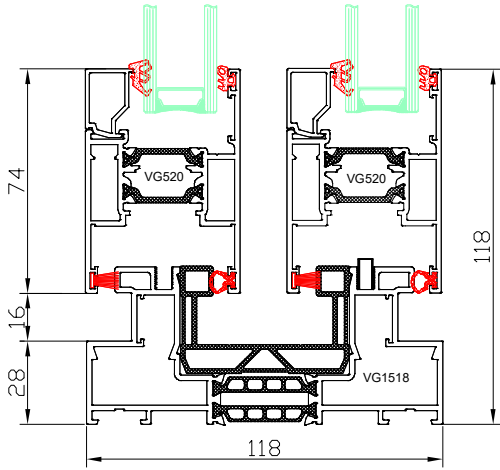

|                     |
|---------------------|
| DA-51 ST            |
| Frame with 2 tracks |
| Frame: VG1518       |
| Sash: VG520         |
| Lowered post: 34 mm |

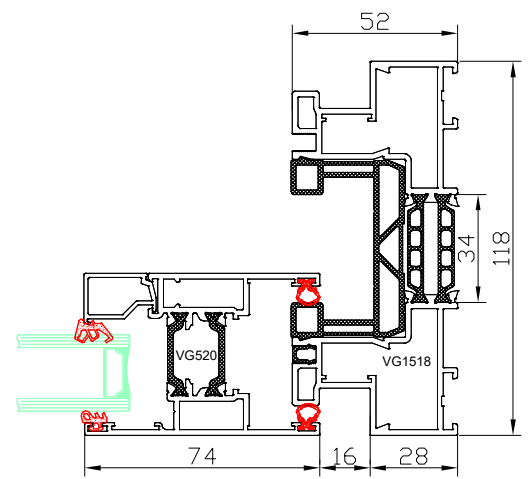
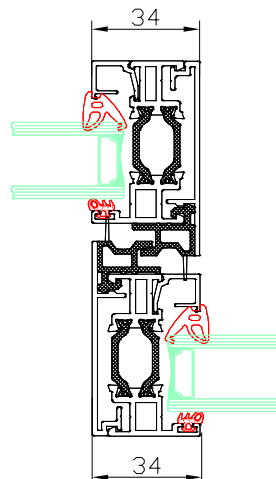
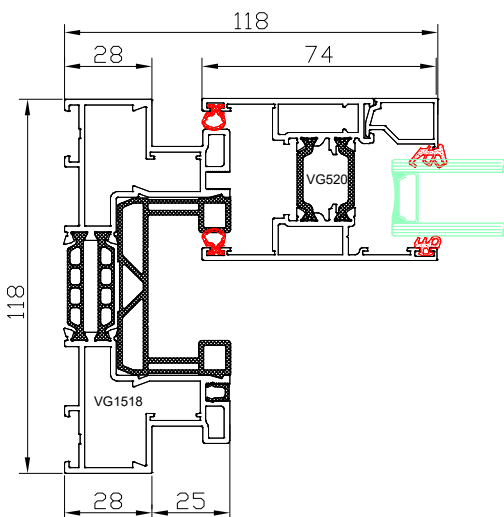



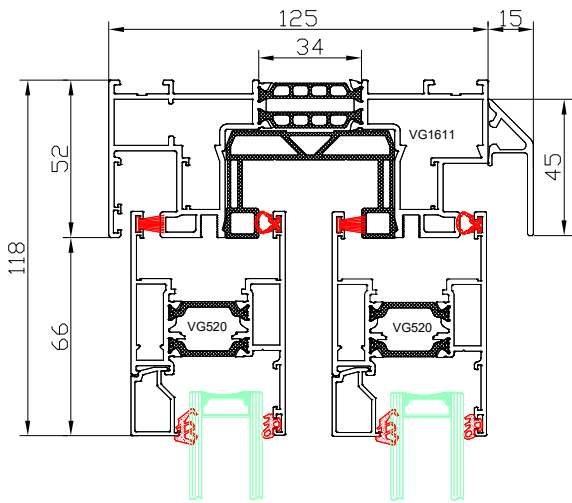

DA-51 ST  
 Frame with 2 tracks and a threshold to be flushed from the inside  
 Frame: VG1611  
 Sash: VG520

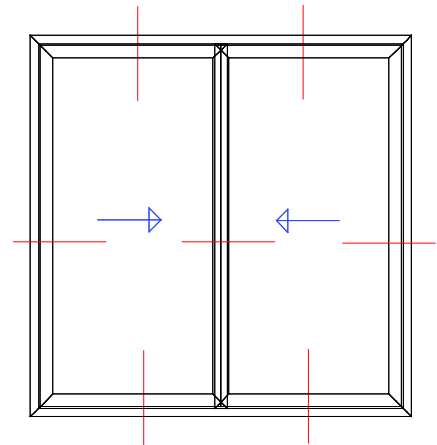
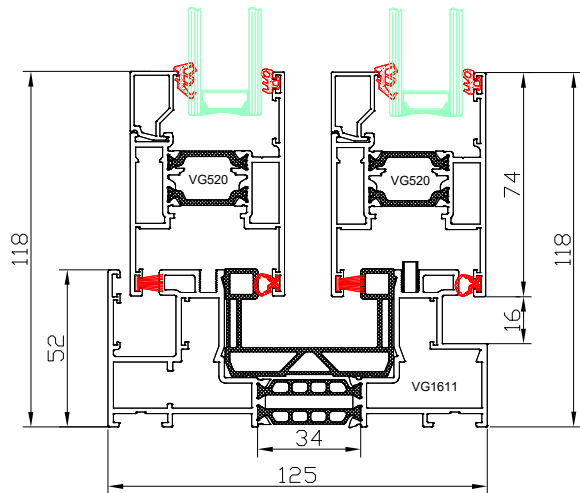

DA-51 ST  
 Frame with 2 tracks and a threshold to be flushed from the inside  
 Frame: VG1611  
 Sash: VG520  
 Post: 84 mm

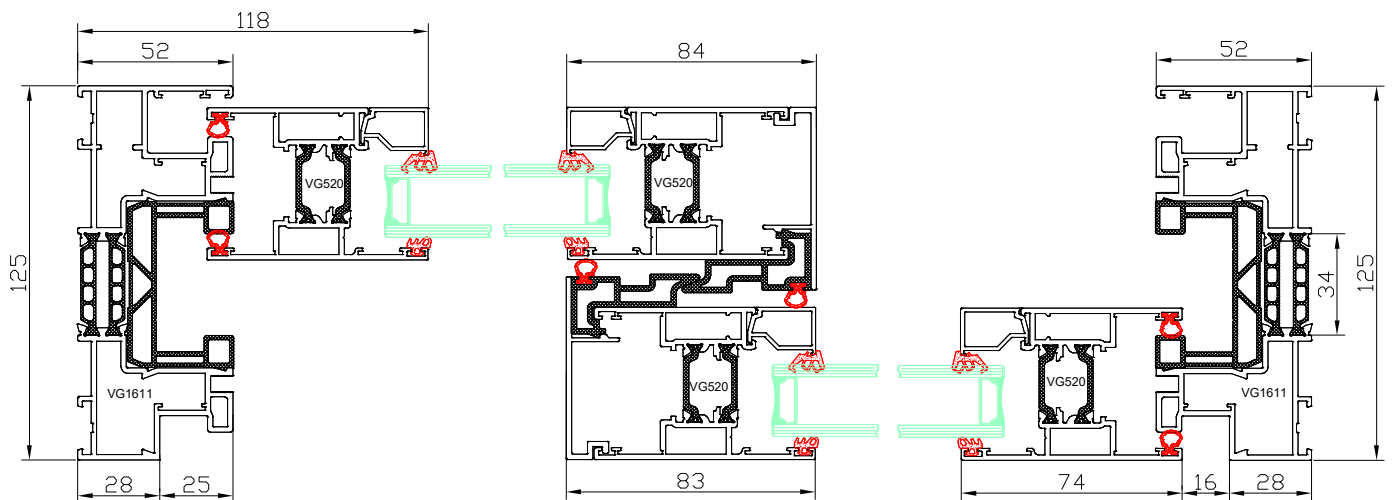

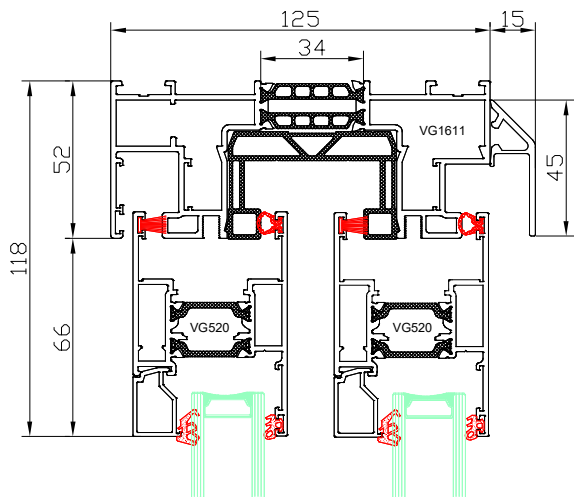

DA-51 ST  
 Frame with 2 tracks and a threshold to be flushed from the inside  
 Frame: VG1611  
 Sash: VG520

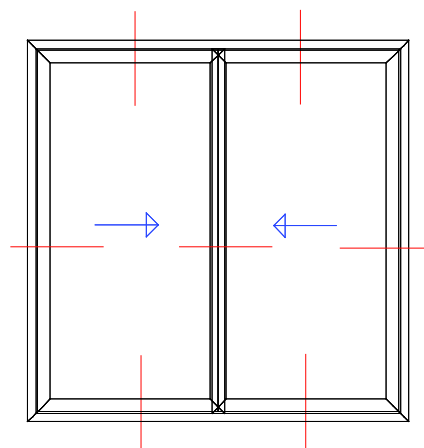
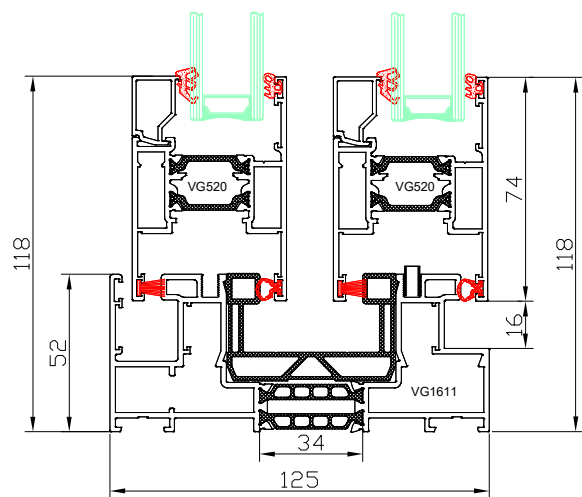

DA-51 ST  
 Frame with 2 tracks and a threshold to be flushed from the inside  
 Frame: VG1611  
 Sash: VG520  
 Lowered post: 34 mm

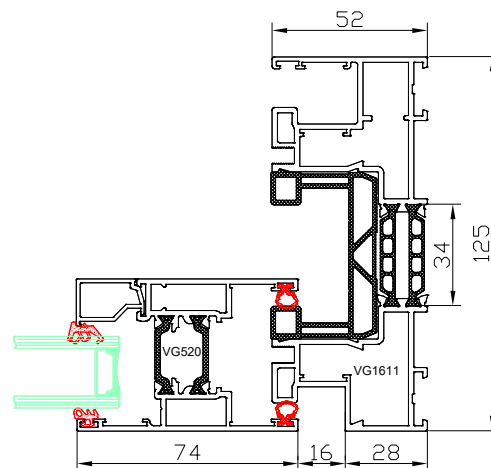
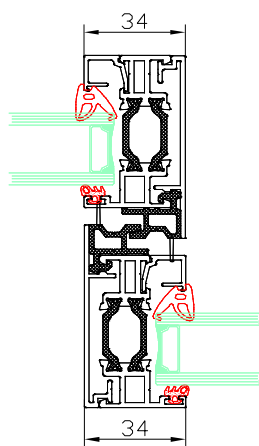
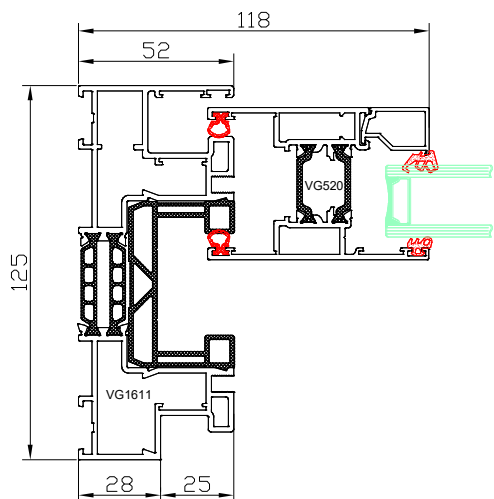

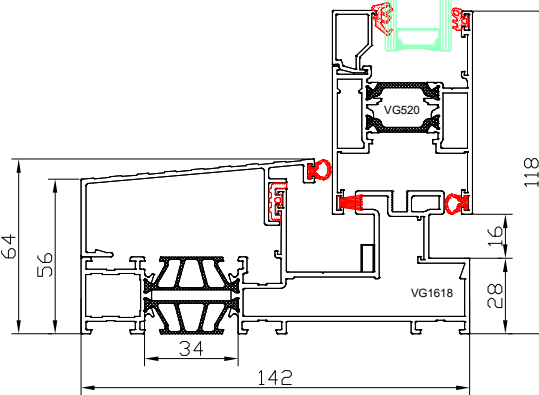
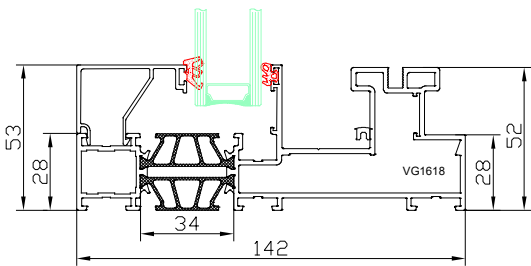
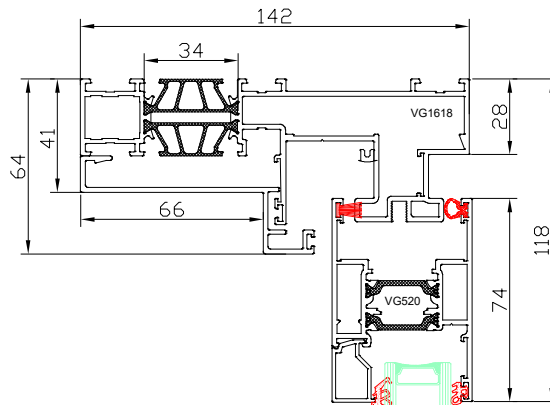
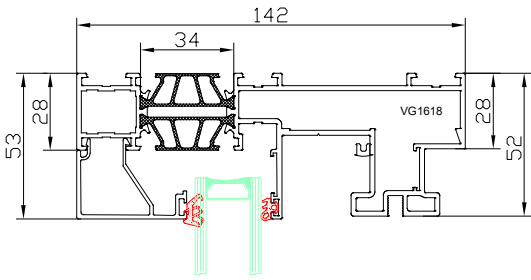

DA-51 ST  
 Frame - monorail (1 track)  
 Frame: VG1618  
 Fixed part

DA-51 ST  
 Frame - monorail (1 track)  
 Frame: VG1618  
 Sash: VG520

DA-51 ST  
 Frame - monorail (1 track)  
 Frame: VG1618  
 Sash: VG520  
 Post: 83 mm

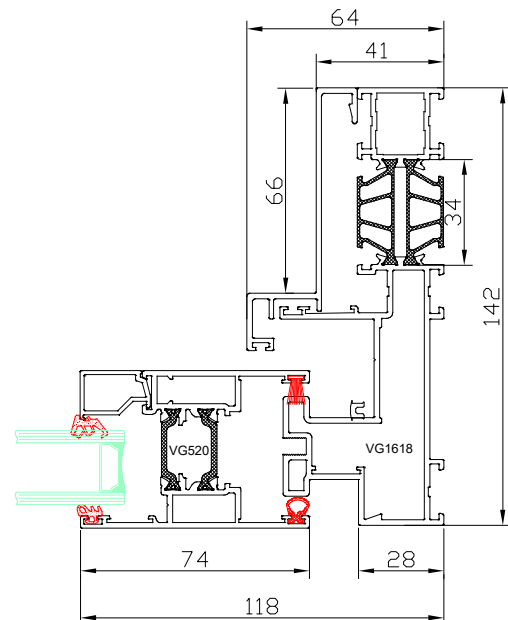
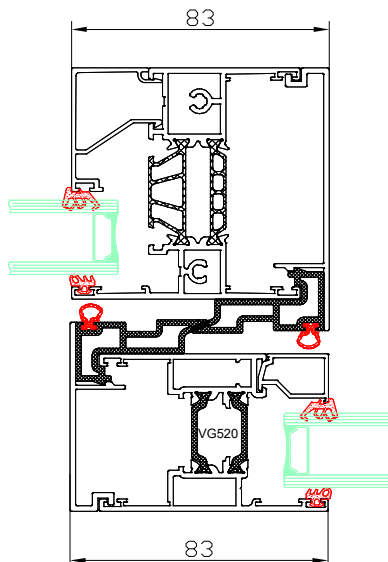
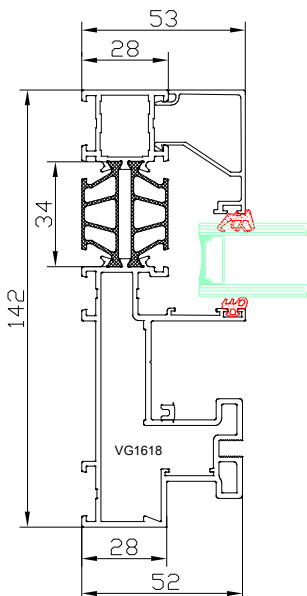

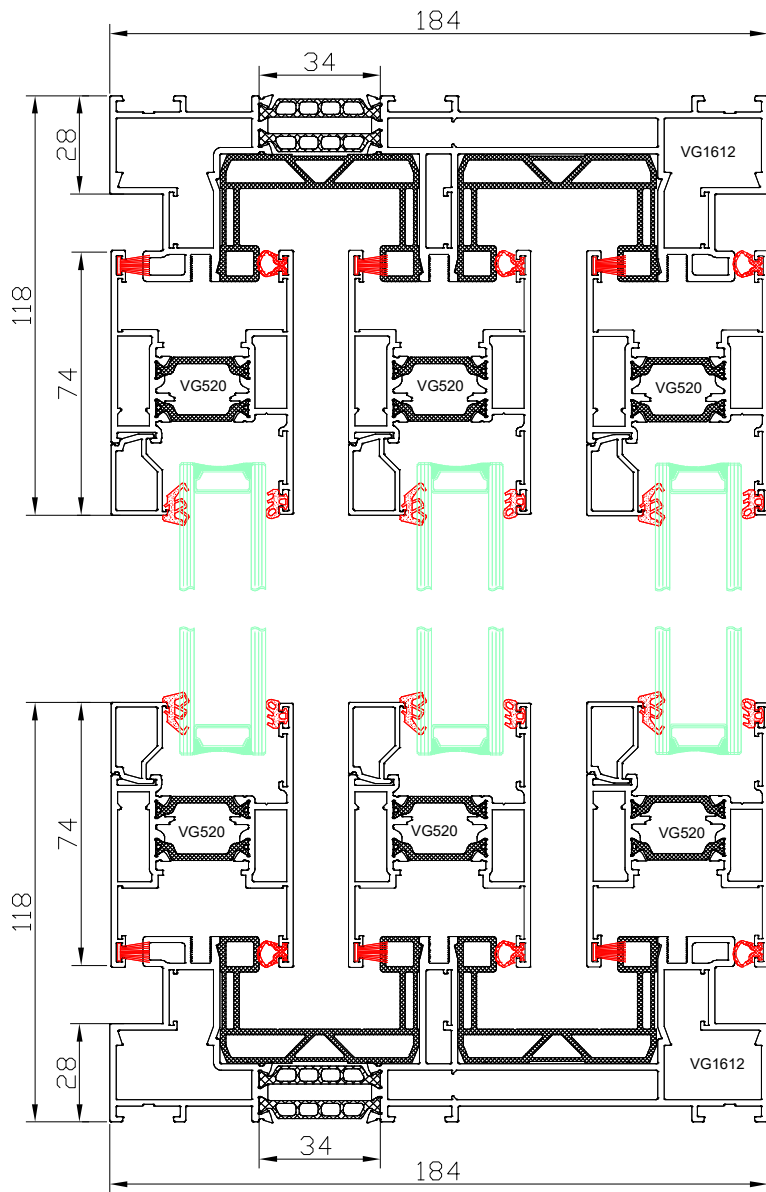

|               |
|---------------|
| DA-51 ST      |
| 3 track frame |
| Frame: VG1612 |
| Sash: VG520   |

|               |
|---------------|
| DA-51 ST      |
| 3 track frame |
| Frame: VG1612 |
| Sash: VG520   |
| Post: 84 mm   |

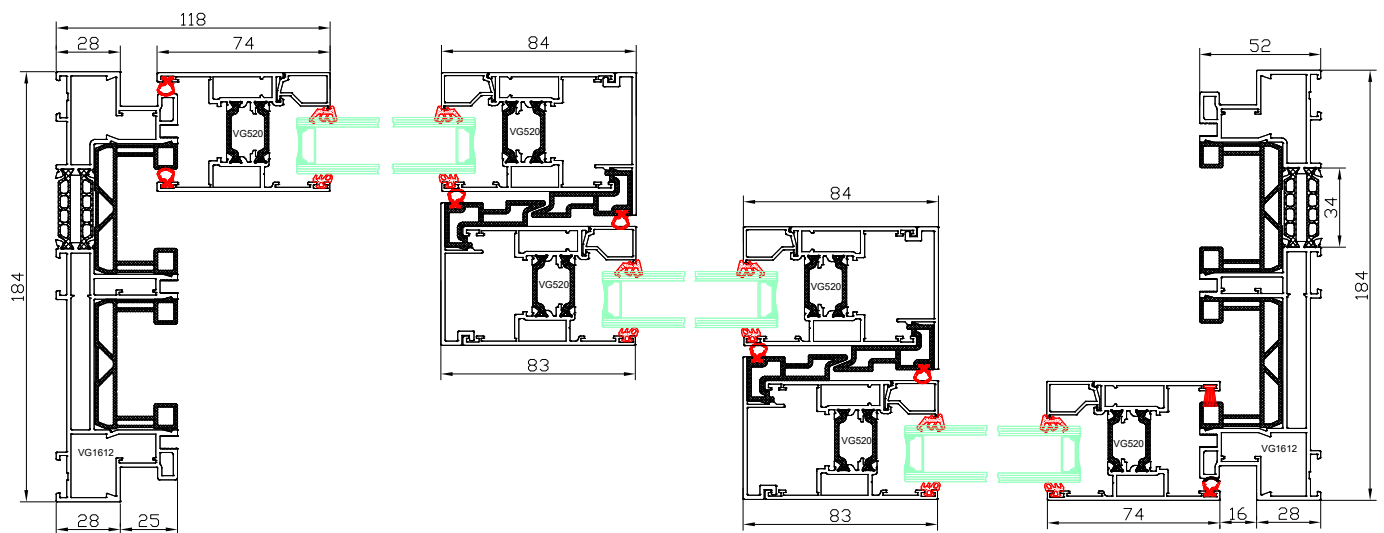

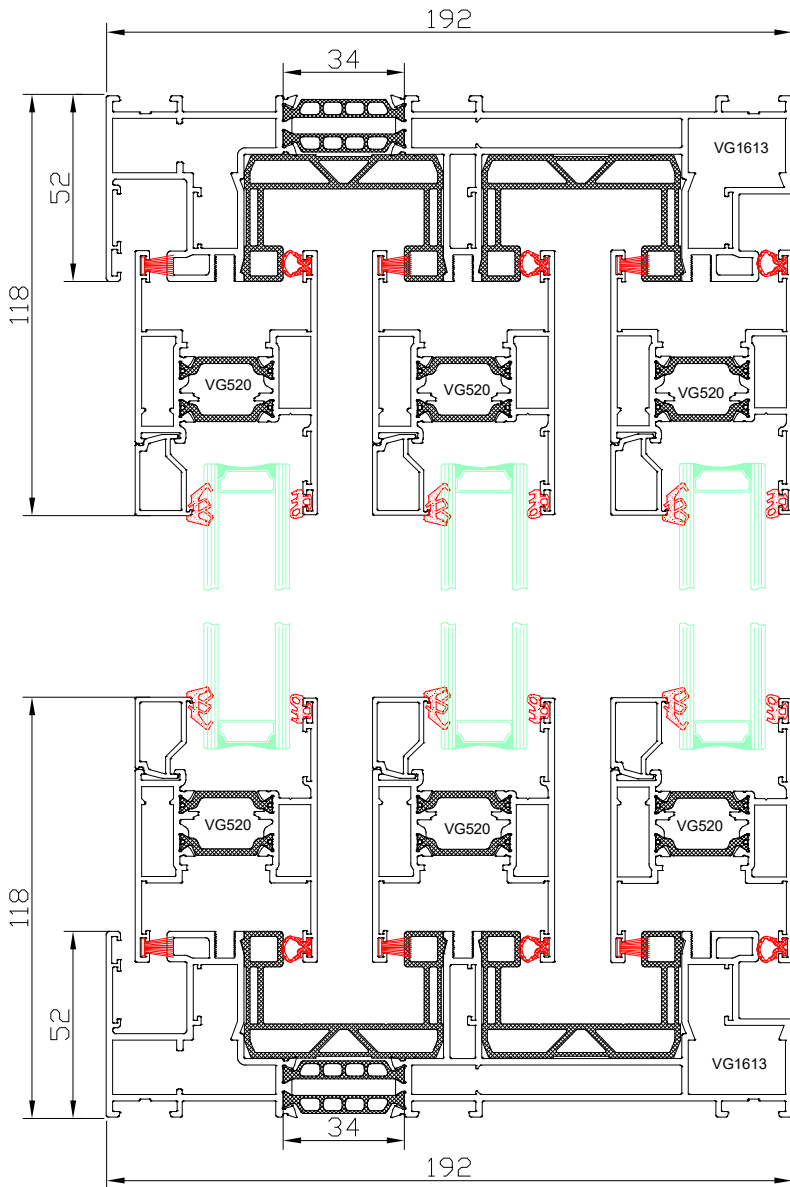

|   |
|---|
| DA-51 ST  |
| Frame with 3 tracks and a threshold to be flushed from the inside |
| Frame: VG1613   |
| Sash: VG520   |

|   |
|---|
| DA-51 ST  |
| Frame with 3 tracks and a threshold to be flushed from the inside |
| Frame: VG1613   |
| Sash: VG520   |
| Post: 84 mm   |

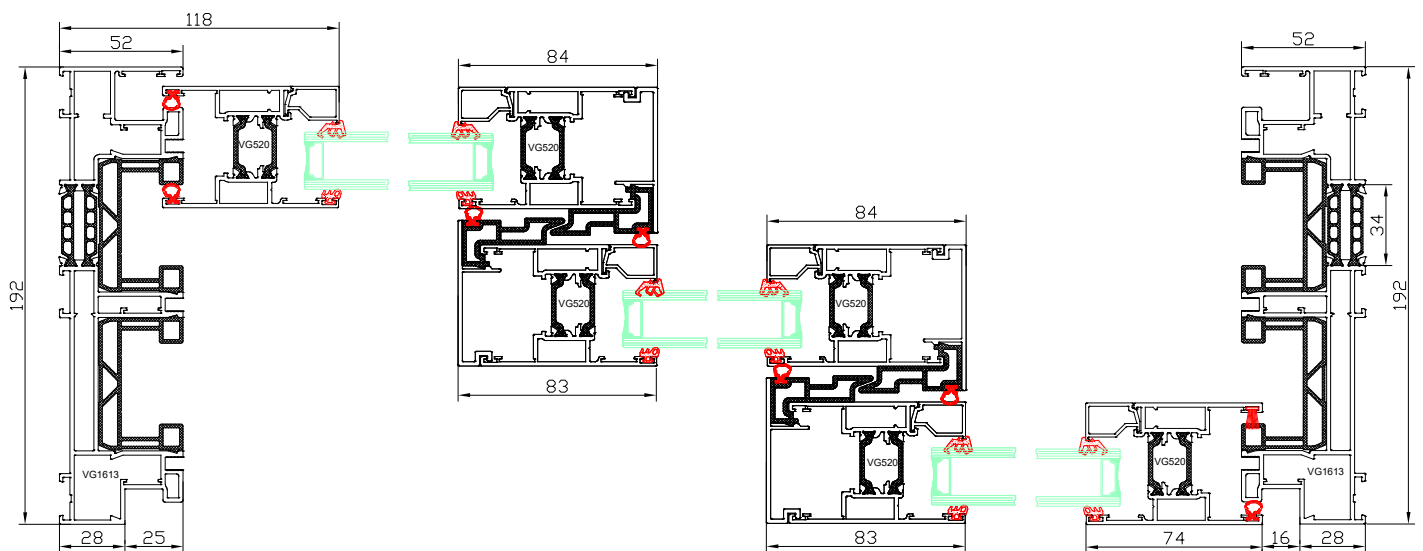



**DA-51 HST**

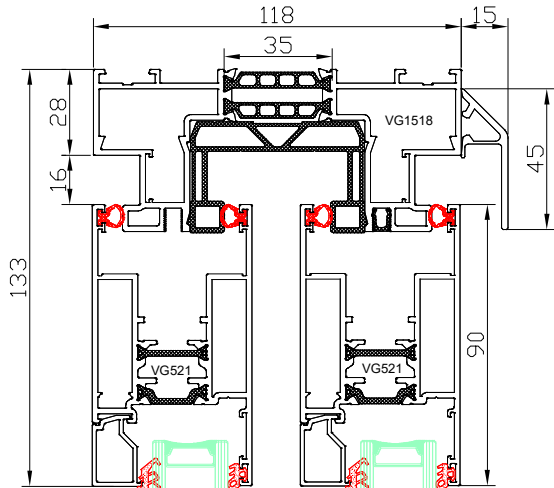

|                               |
|-------------------------------|
| DA-51 HST                     |
| Frame with 2 tracks, 2 sashes |
| Frame: VG1518                 |
| Sash: VG521                   |

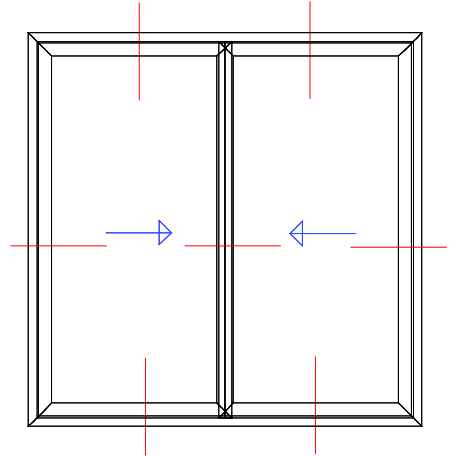
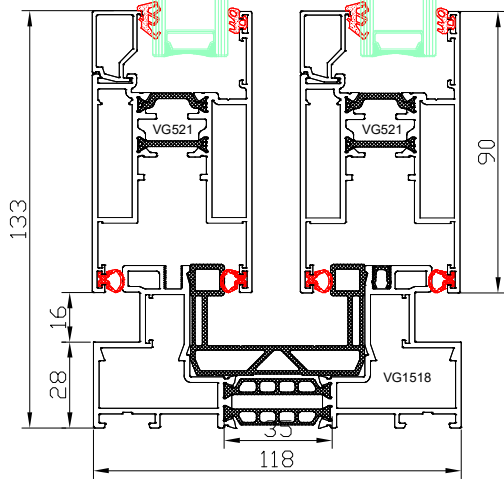

|                               |
|-------------------------------|
| DA-51 HST                     |
| Frame with 2 tracks, 2 sashes |
| Frame: VG1518                 |
| Sash: VG521                   |
| Post: 100 mm                  |

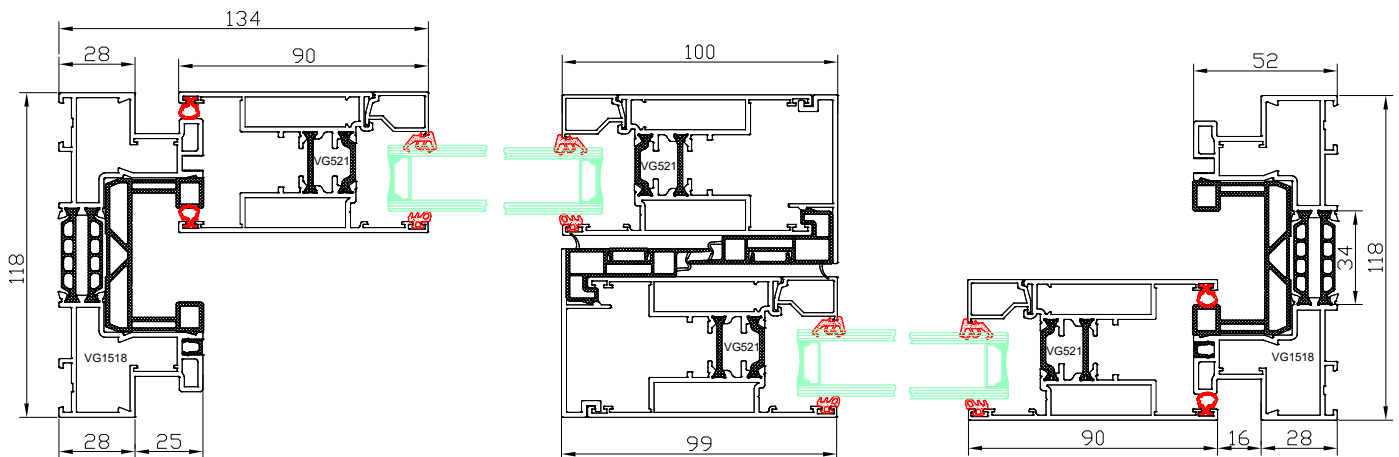

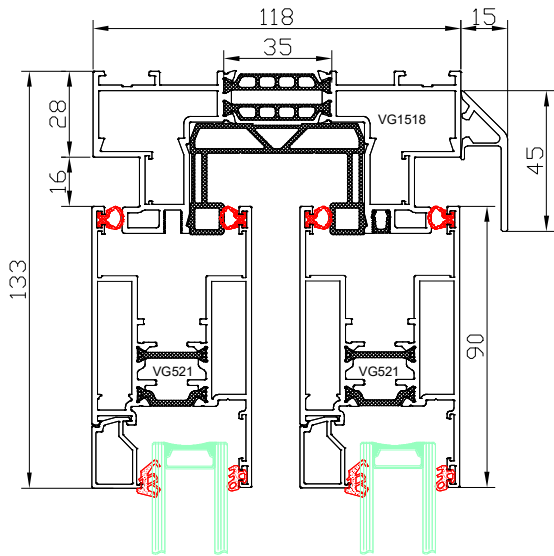

DA-51 HST  
 Frame, 1 sash with a low threshold  
 for the disabled  
 Frame: VG1516  
 Sash: VG521

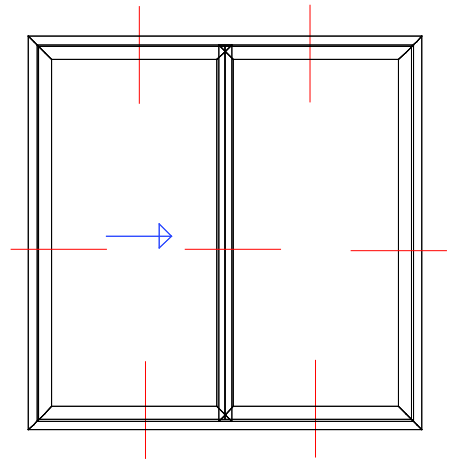
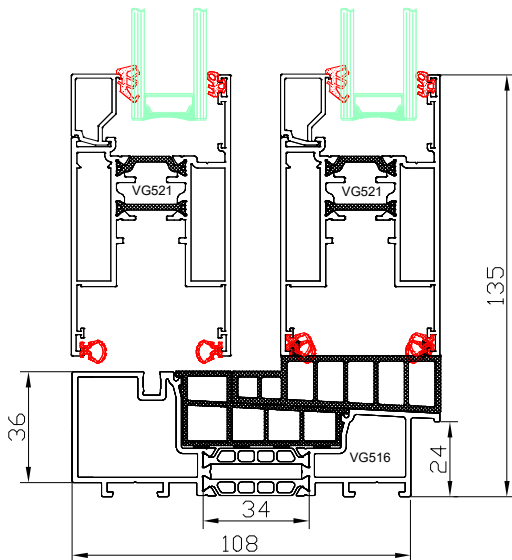

DA-51 HST  
 Frame, 1 sash with a low threshold  
 for the disabled  
 Frame: VG1518  
 Sash: VG521  
 Post: 100 mm

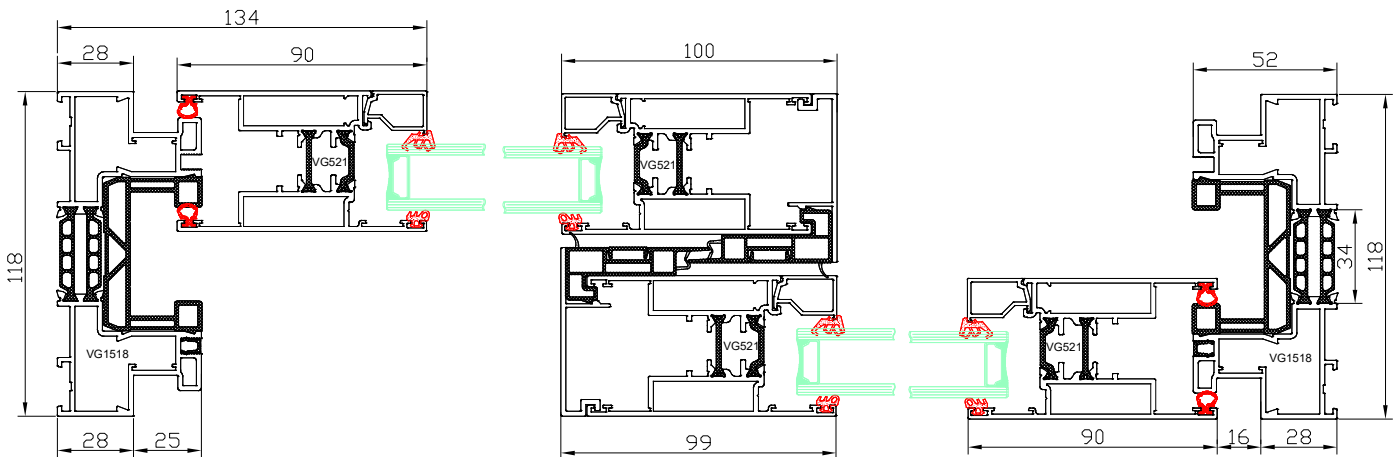



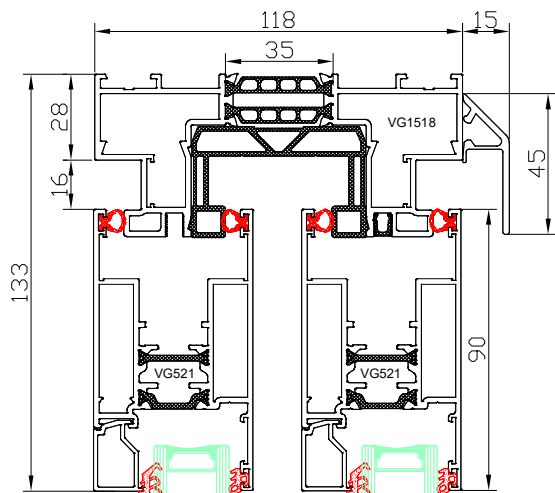

|                               |
|-------------------------------|
| DA-51 HST                     |
| Frame with 2 tracks, 2 sashes |
| Frame: VG1518                 |
| Sash: VG521                   |

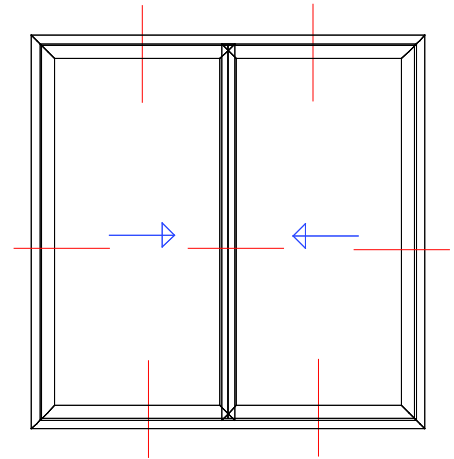
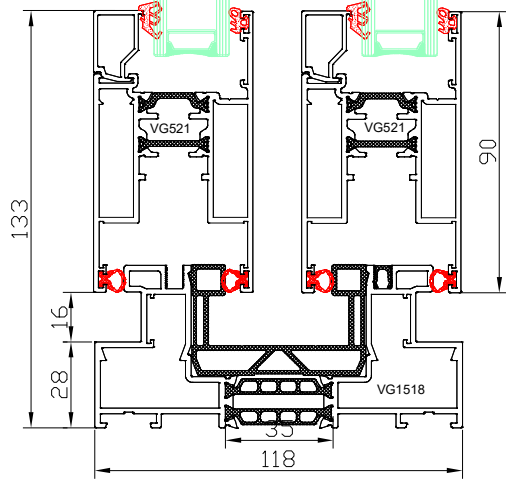

|                               |
|-------------------------------|
| DA-51 HST                     |
| Frame with 2 tracks, 2 sashes |
| Frame: VG1518                 |
| Sash: VG521                   |
| Lowered post: 34 mm           |

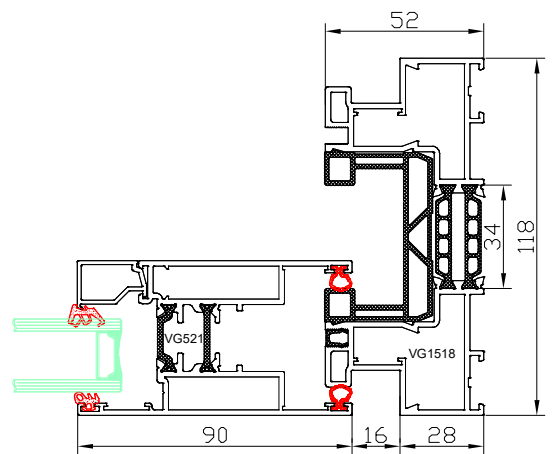
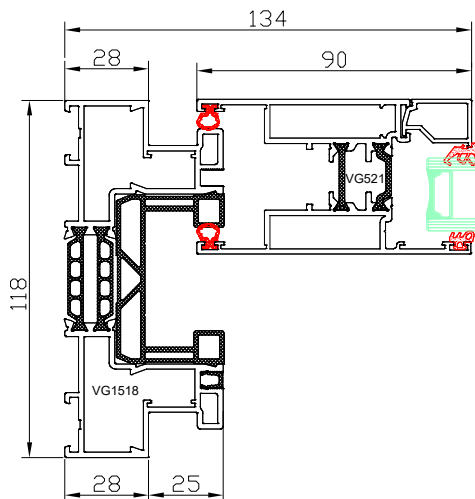

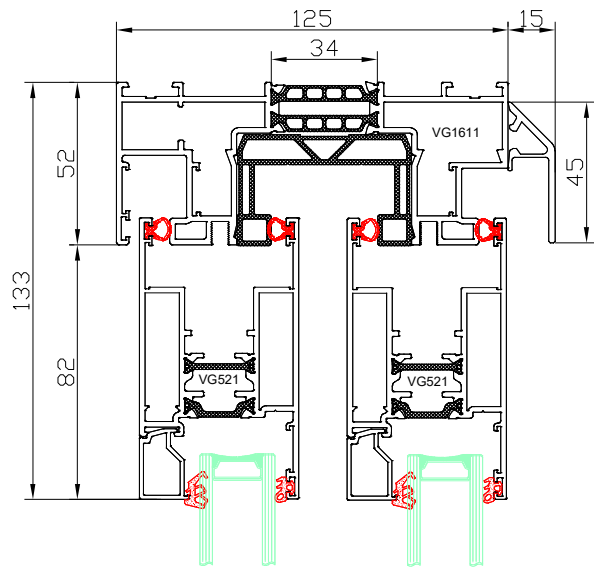

DA-51 HST  
 Frame with 2 tracks and a threshold to be flushed from the inside  
 Frame: VG1611  
 Sash: VG521

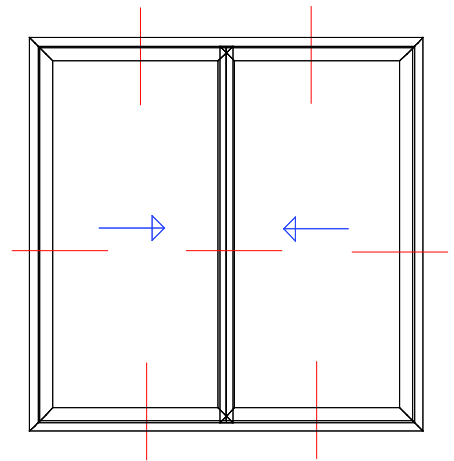
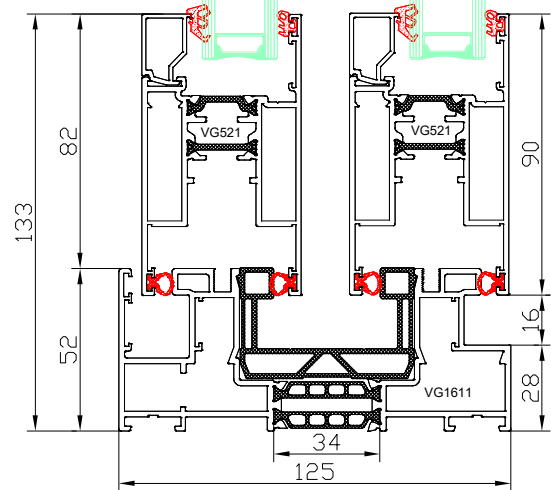

DA-51 HST  
 Frame with 2 tracks and a threshold to be flushed from the inside  
 Frame: VG1611  
 Sash: VG521  
 Post: 100 mm

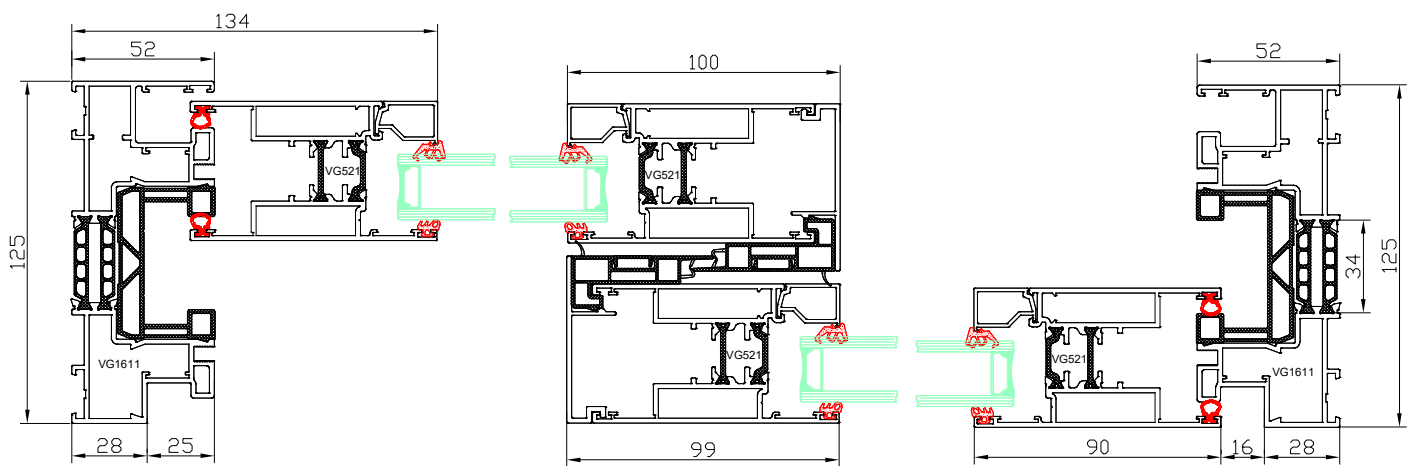

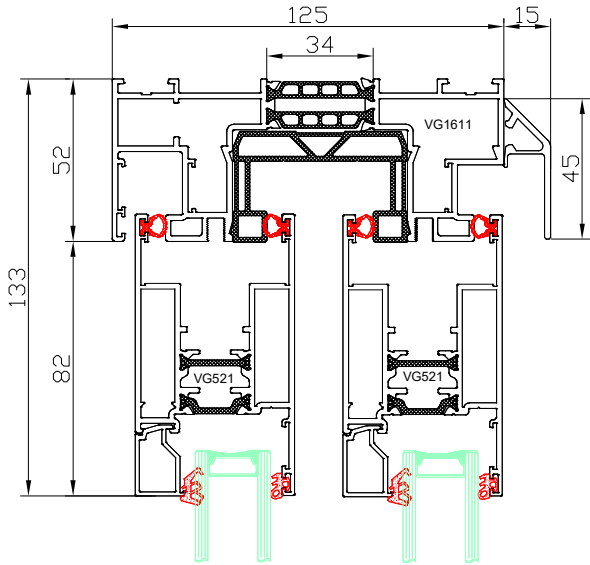

DA-51 HST  
 Frame with 2 tracks and a threshold to be flushed from the inside  
 Frame: VG1611  
 Sash: VG521

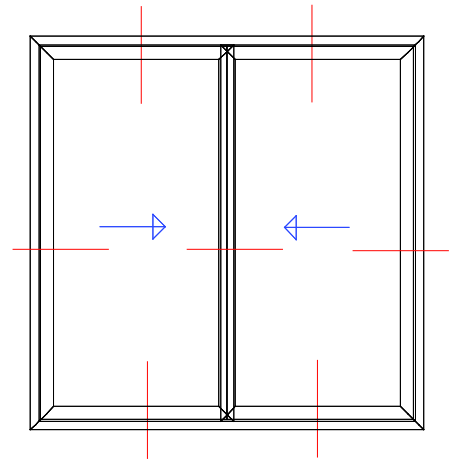
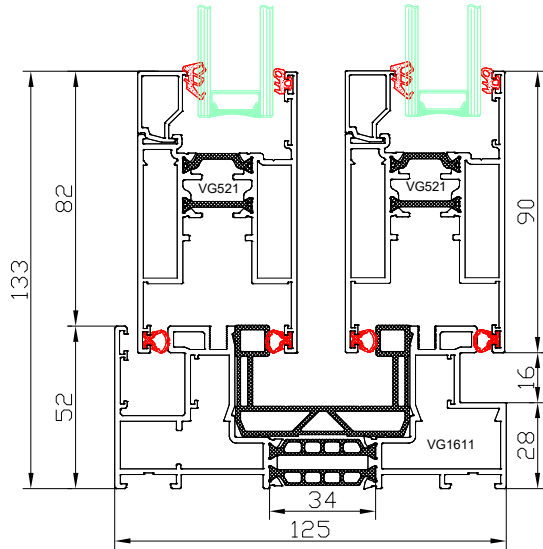

DA-51 HST  
 Frame with 2 tracks and a threshold to be flushed from the inside  
 Frame: VG1611  
 Sash: VG521  
 Lowered post: 34 mm

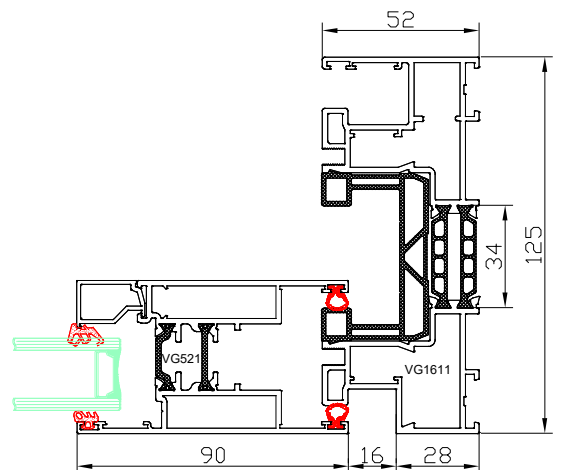
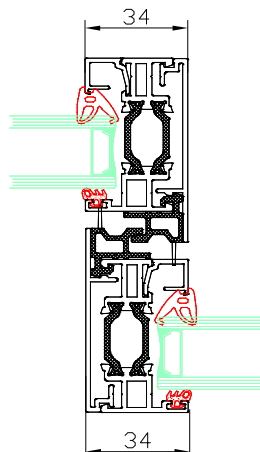
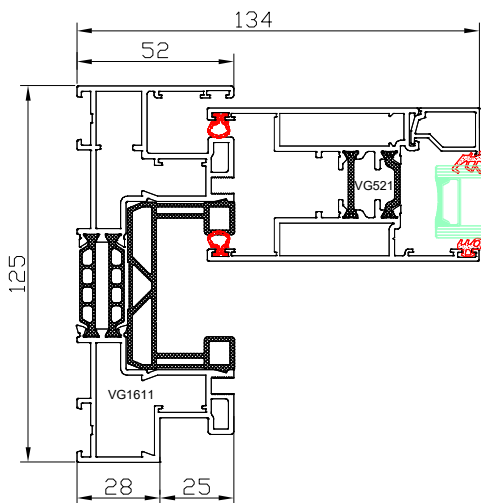

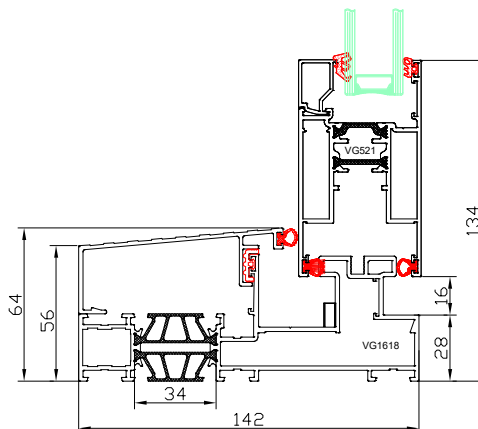
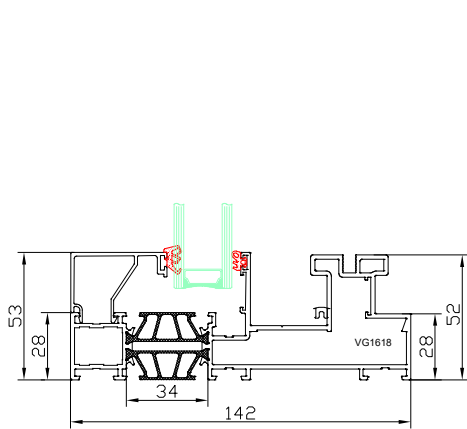
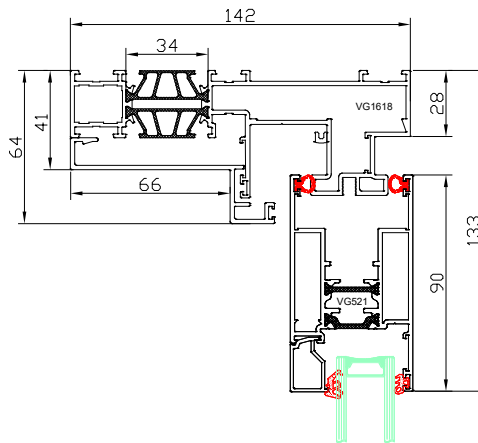
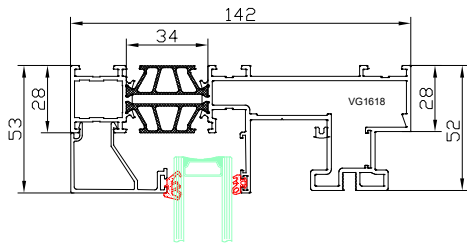

DA-51 HST  
Frame - monorail (1 track)  
Frame: VG1618 (Fixed part)

DA-51 HST  
Frame - monorail (1 track)  
Frame: VG1618  
Sash: VG521

DA-51 HST  
Frame - monorail (1 track)  
Frame: VG1618  
Sash: VG521  
Post: 100 mm

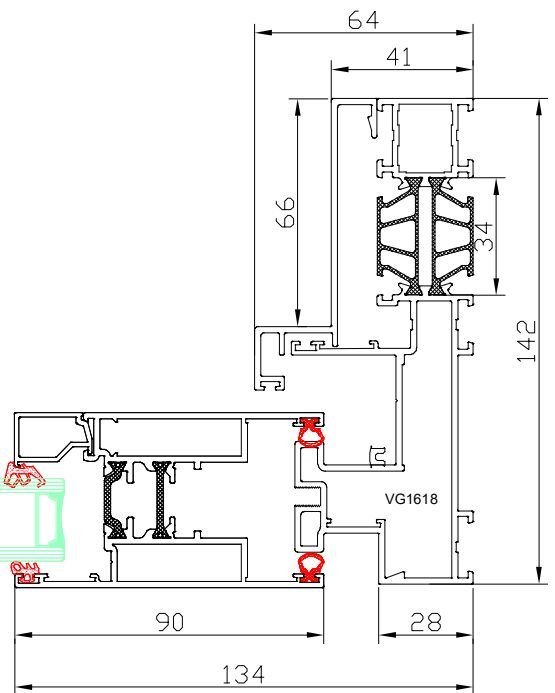
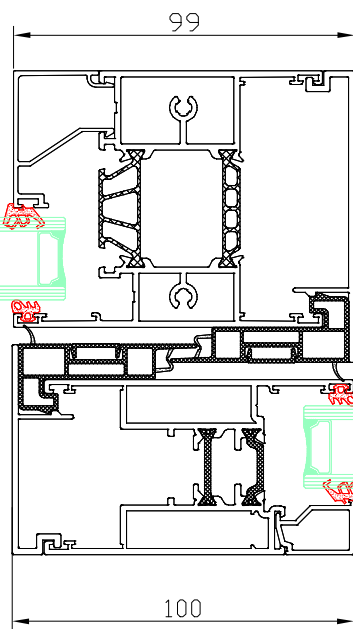
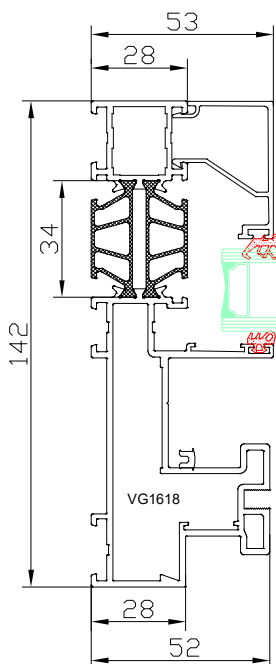

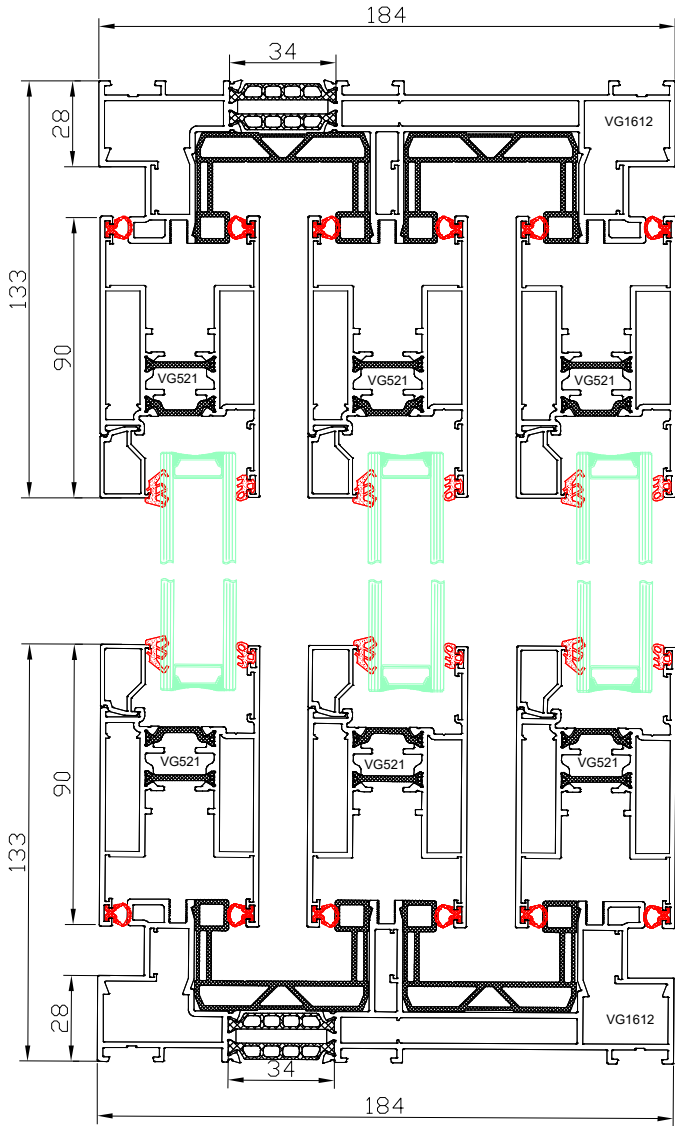

|               |
|---------------|
| DA-51 HST     |
| 3 track frame |
| Frame: VG1612 |
| Sash: VG521   |

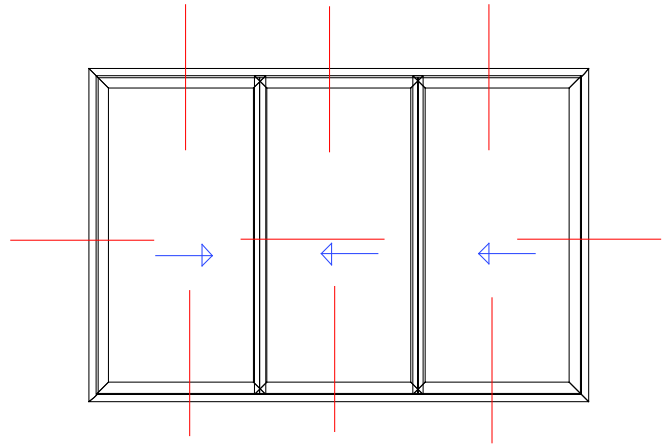

|               |
|---------------|
| DA-51 HST     |
| 3 track frame |
| Frame: VG1612 |
| Sash: VG521   |
| Post: 100 mm  |

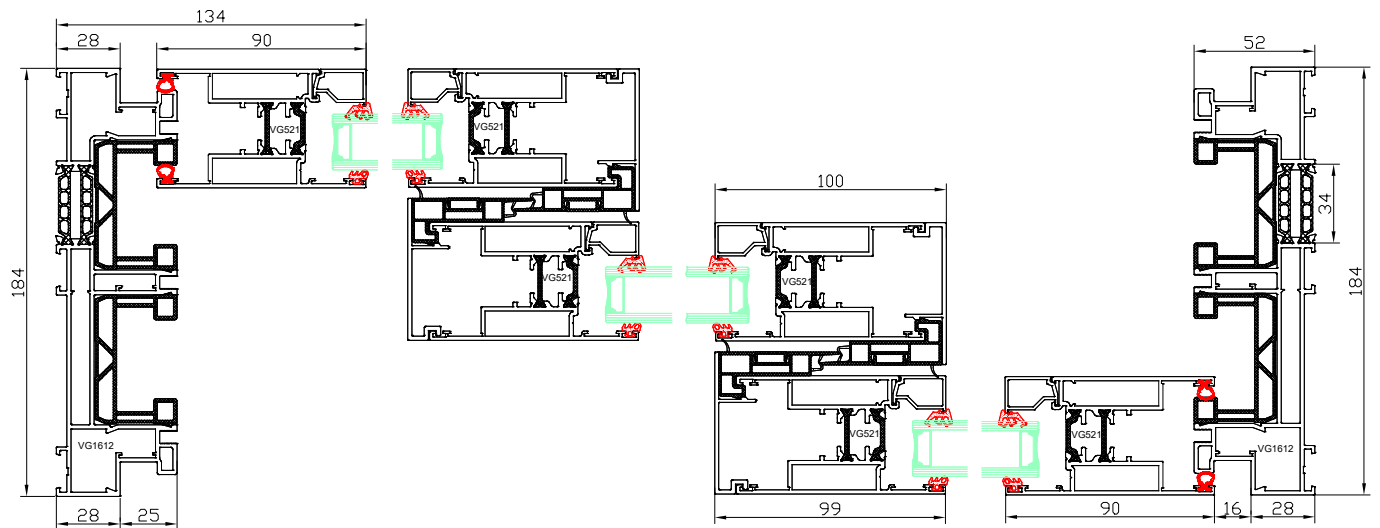

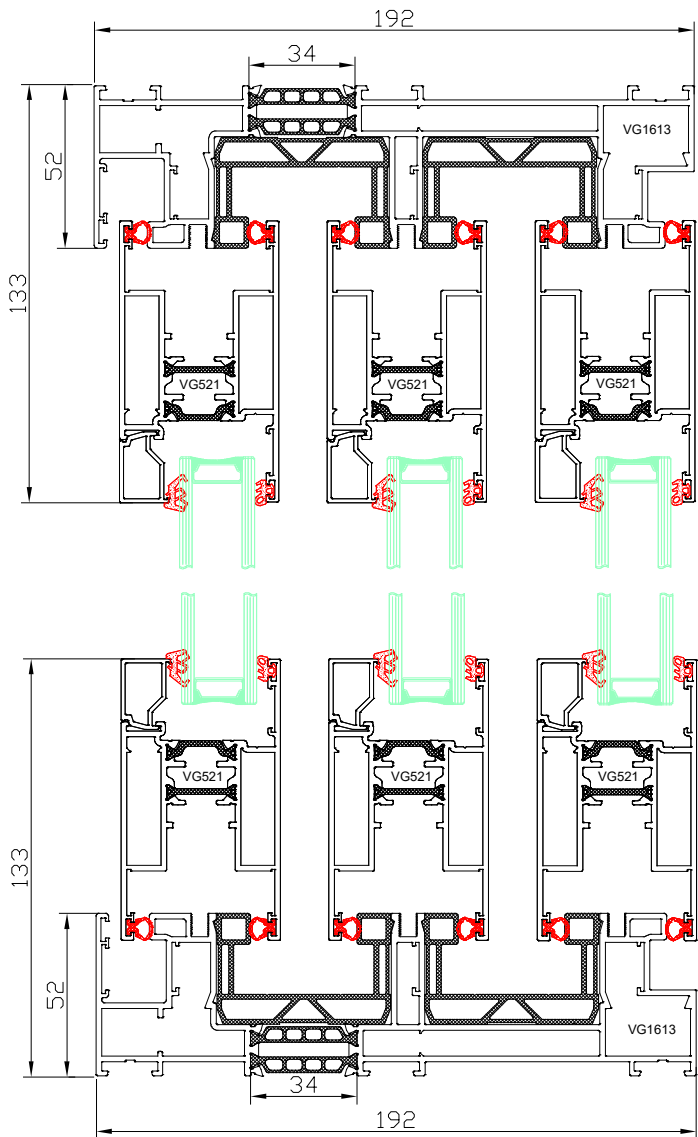

DA-51 HST  
 Frame with 3 tracks and a threshold  
 to be flushed from the inside  
 Frame: VG1613  
 Sash: VG521

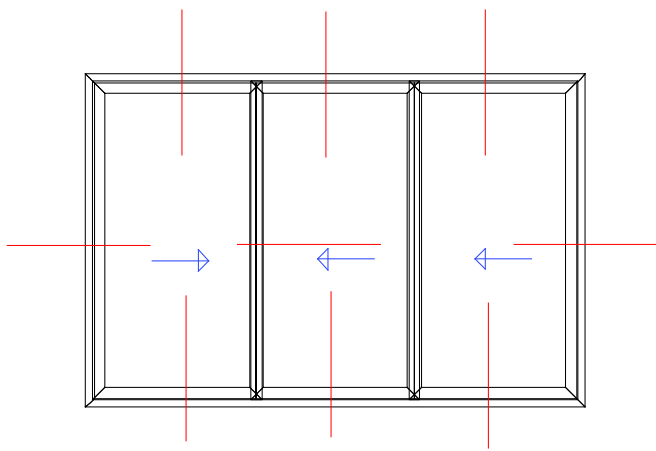

DA-51 HST  
 Frame with 3 tracks and a threshold  
 to be flushed from the inside  
 Frame: VG1613  
 Sash: VG521  
 Post: 100 mm

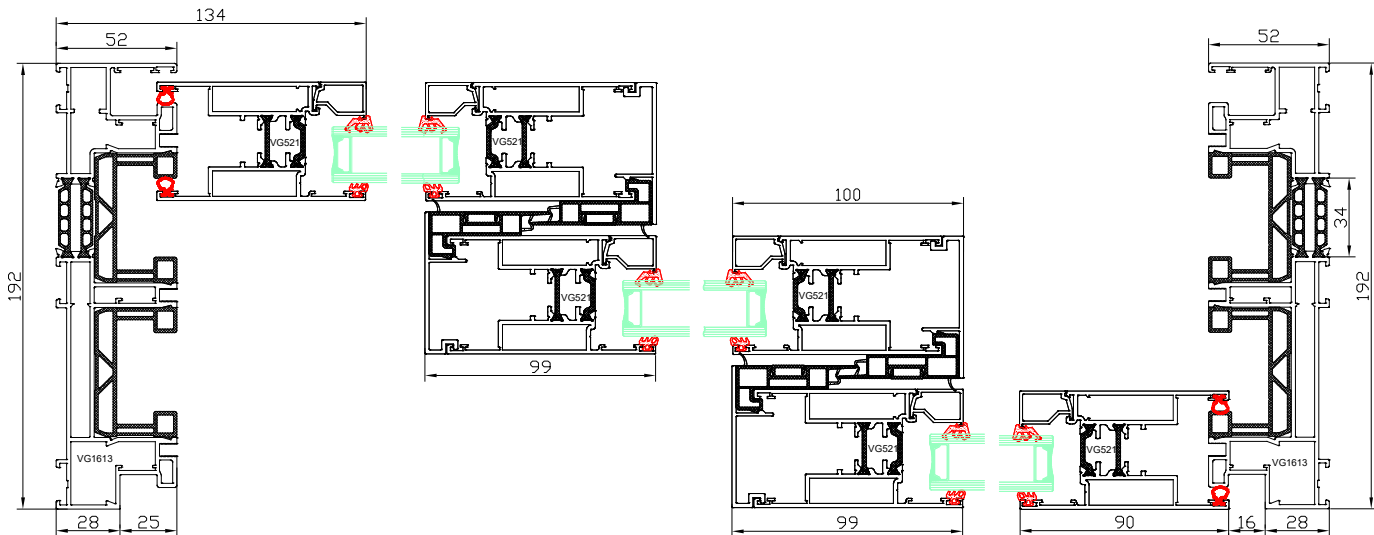

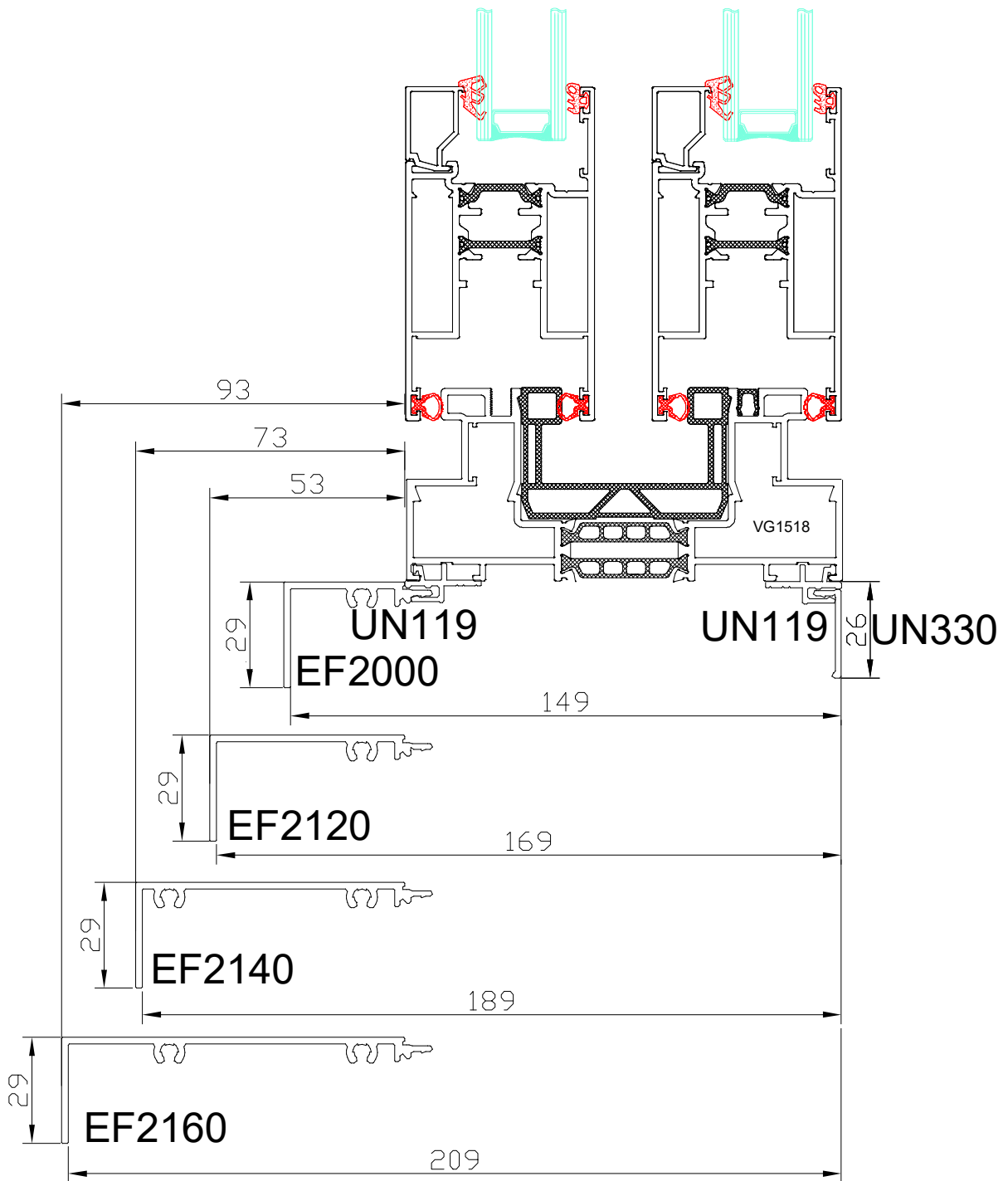

DA-51 HST / DA-51 ST  
Cover profiles

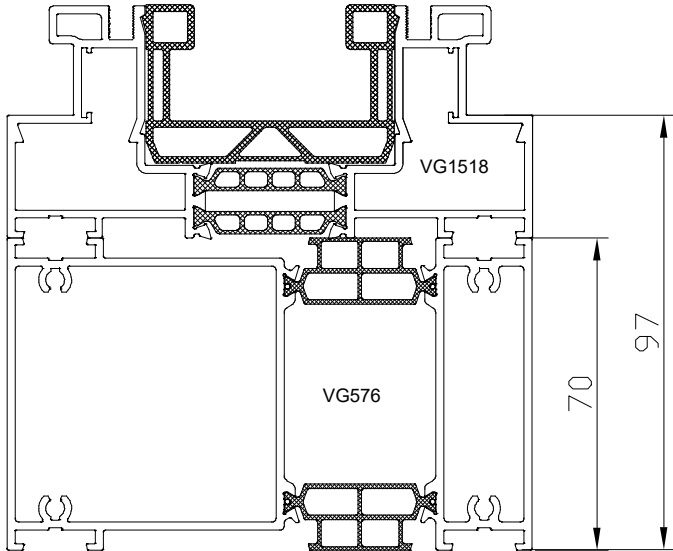

DA-51 HST / DA-51 ST  
Expander VG576

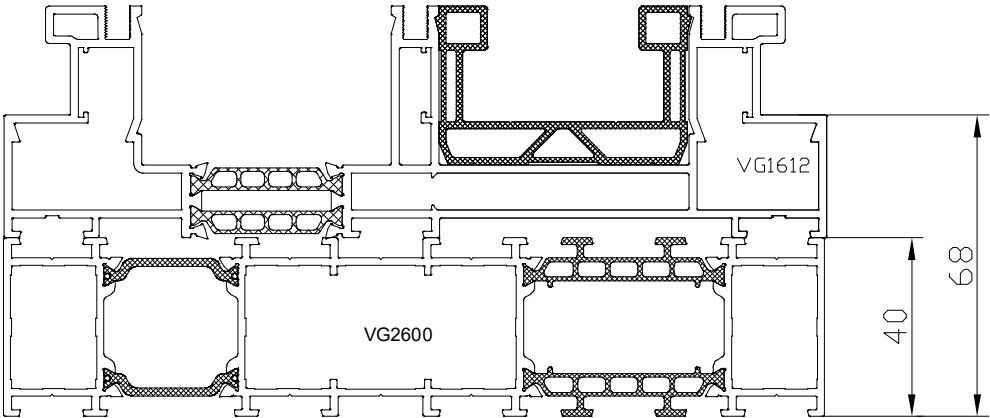

DA-51 HST / DA-51 ST  
Expander VG2600





## DA-77N PANEL DOORS

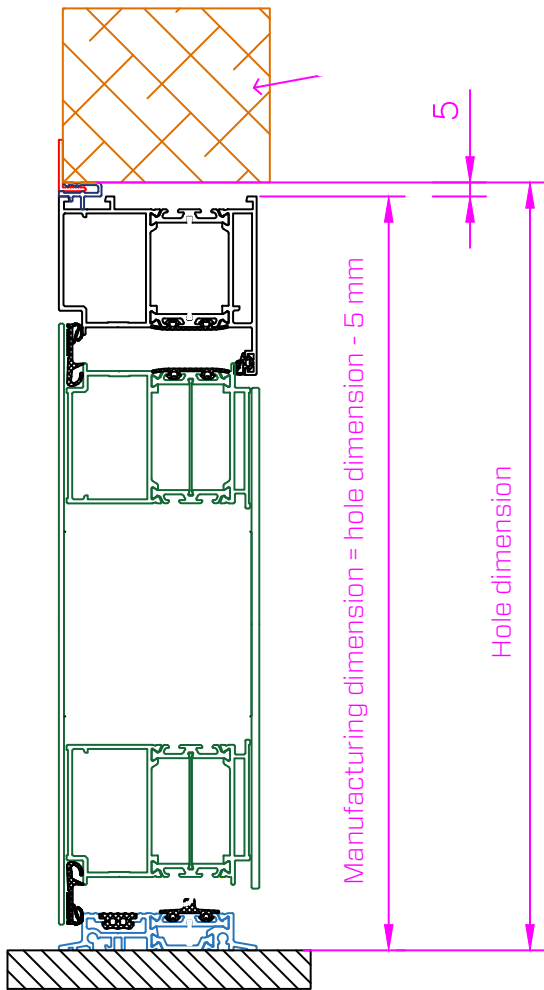

K413929 + K413926

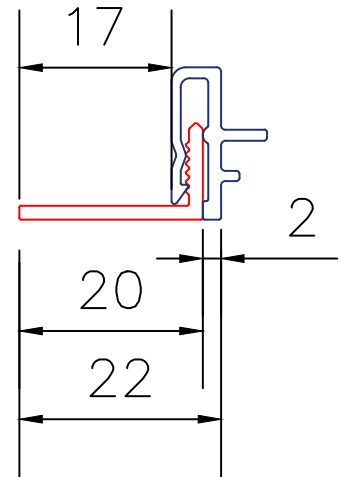

DA-77N  
Renovation assembly - profile DA-77N panel doors  
- sahes on 3 sides: D, G, H

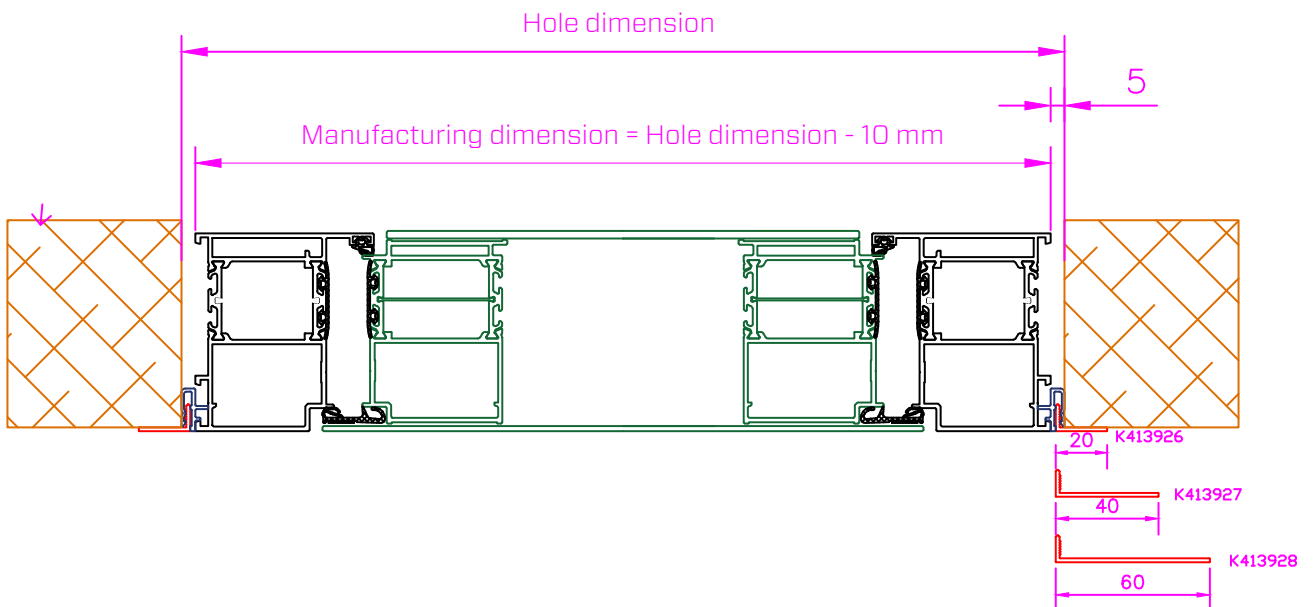

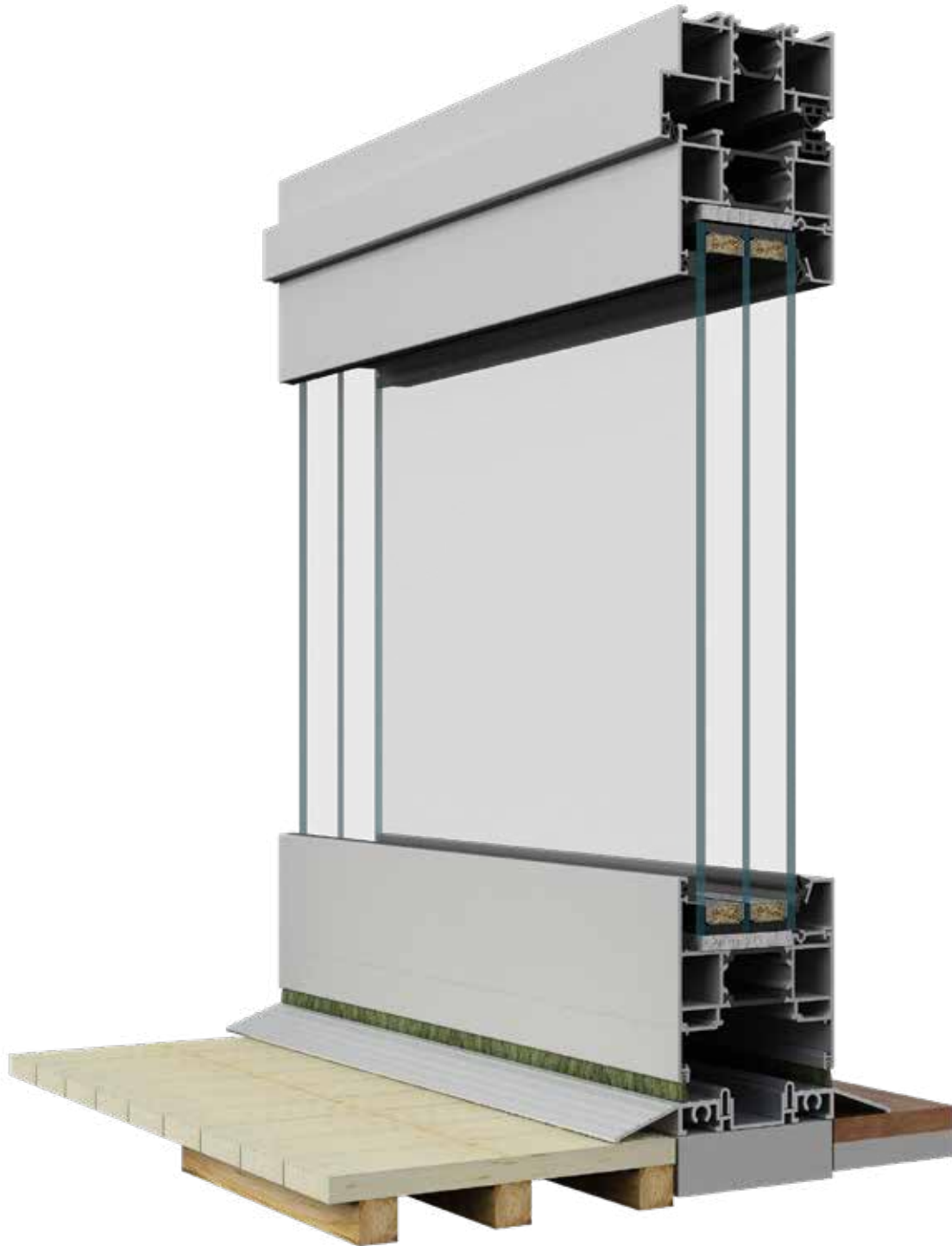

# DA-77 FD FOLDING DOOR

DA-77 FD  
Possible inward opening models

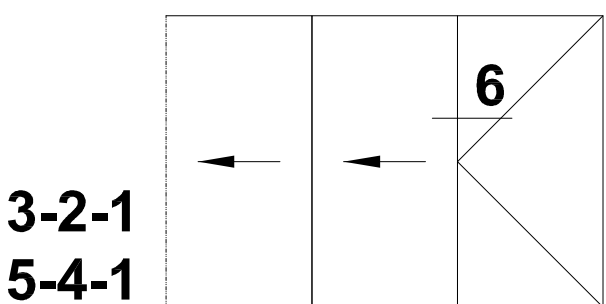
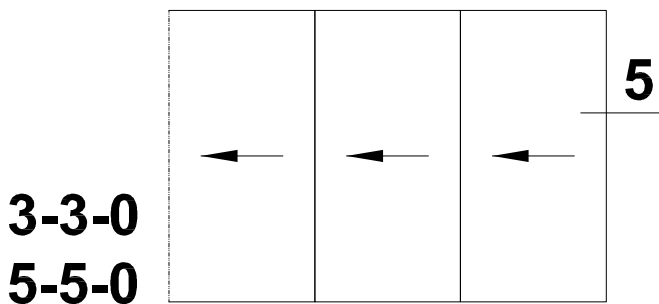
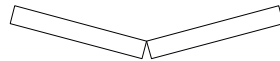
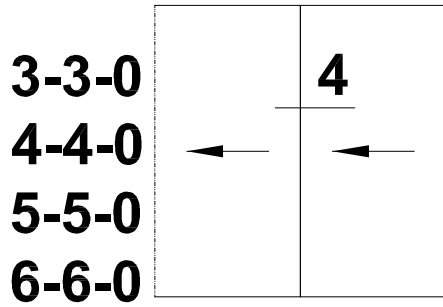
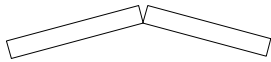
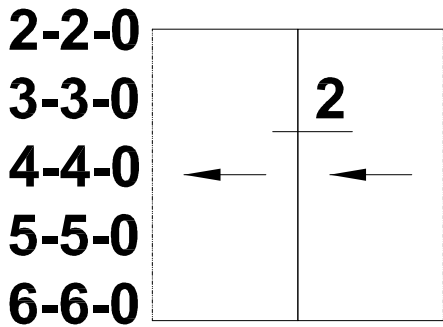
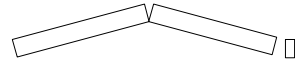
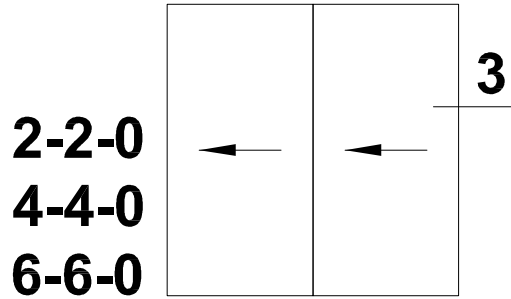
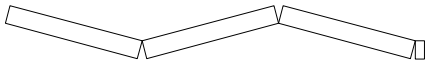
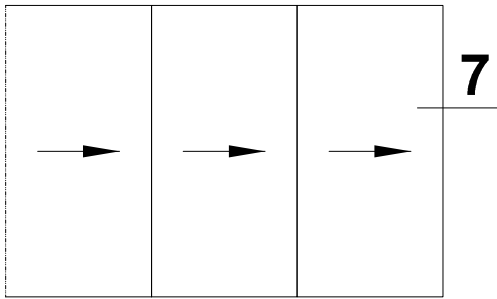
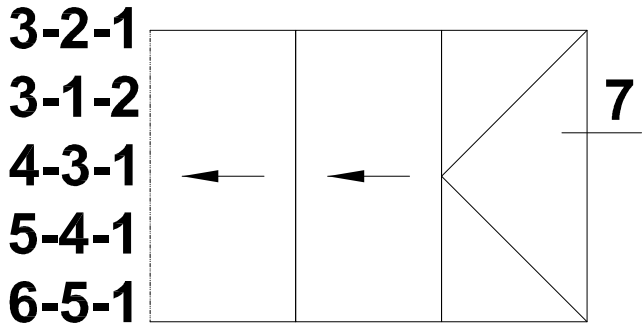
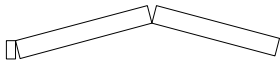
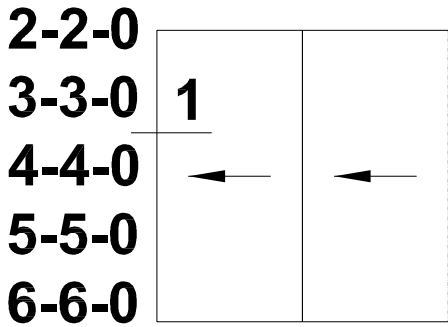

DA-77 FD  
Possible inward opening models

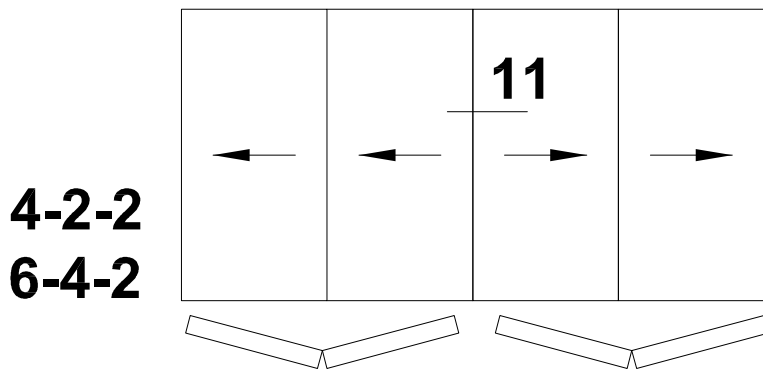
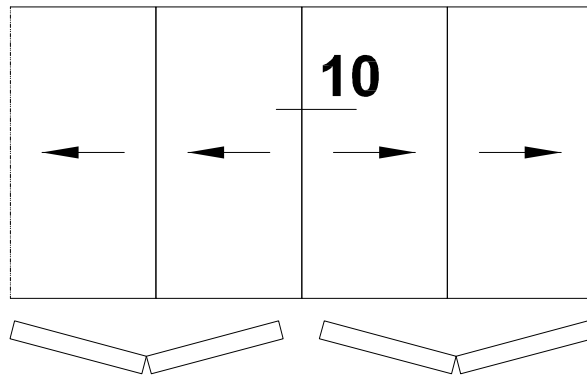
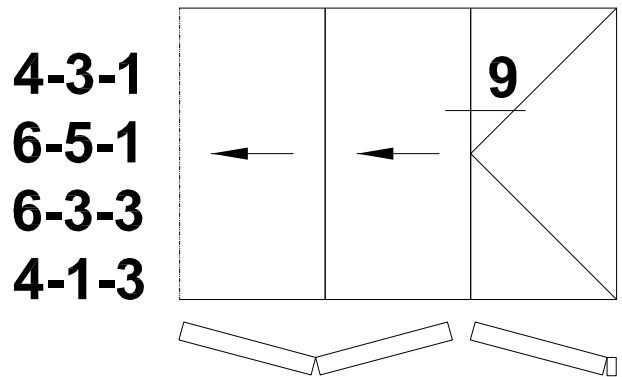
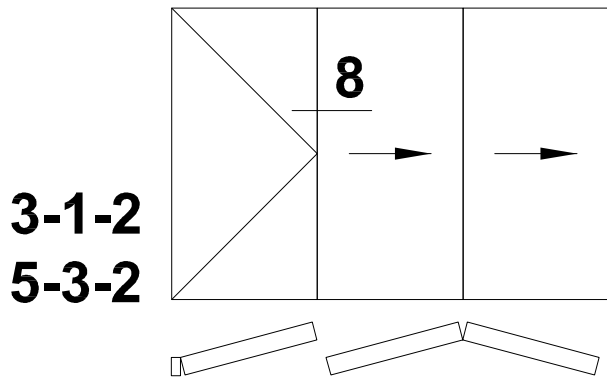

DA-77 FD  
Possible outward opening models

2-2-0  
3-3-0  
4-4-0  
5-5-0  
6-6-0

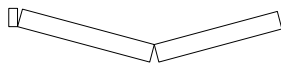
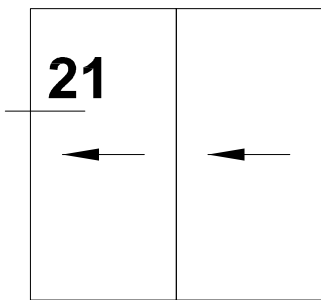

3-2-1  
3-1-2  
4-3-1  
5-4-1  
6-5-1

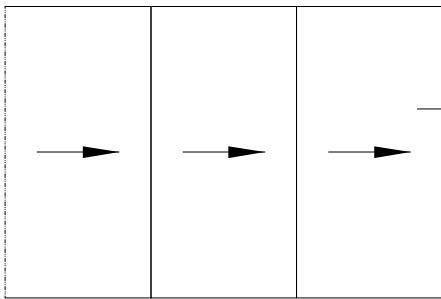
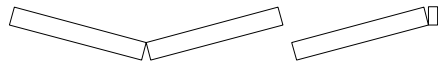
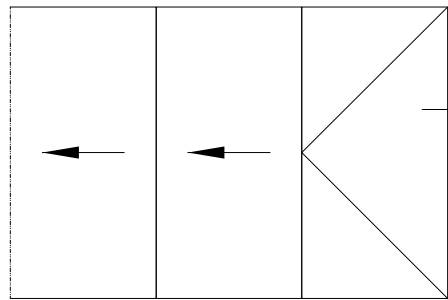

27

2-2-0  
4-4-0  
6-6-0

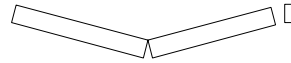
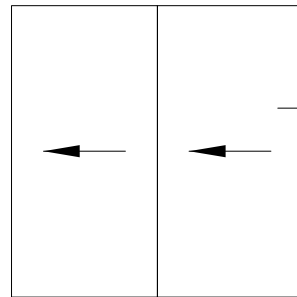

23

2-2-0  
3-3-0  
4-4-0  
5-5-0  
6-6-0

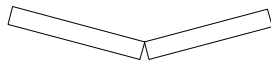
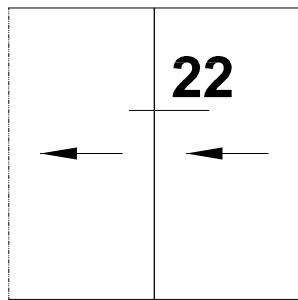

22

3-3-0  
4-4-0  
5-5-0  
6-6-0

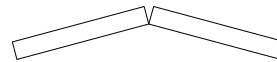
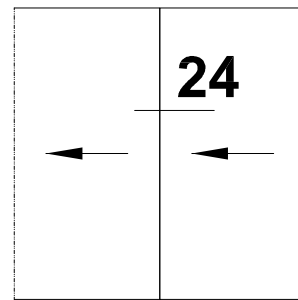

24

3-3-0  
5-5-0

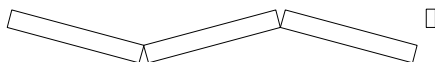
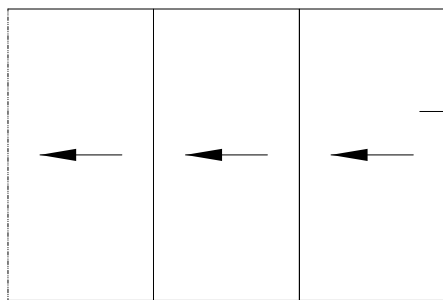

25

3-2-1  
5-4-1

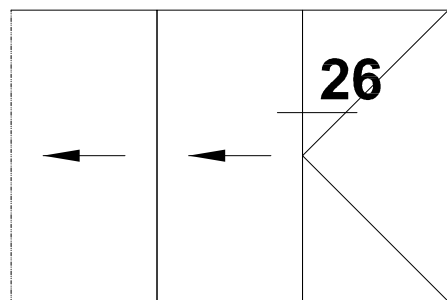

26

DA-77 FD  
Possible outward opening models

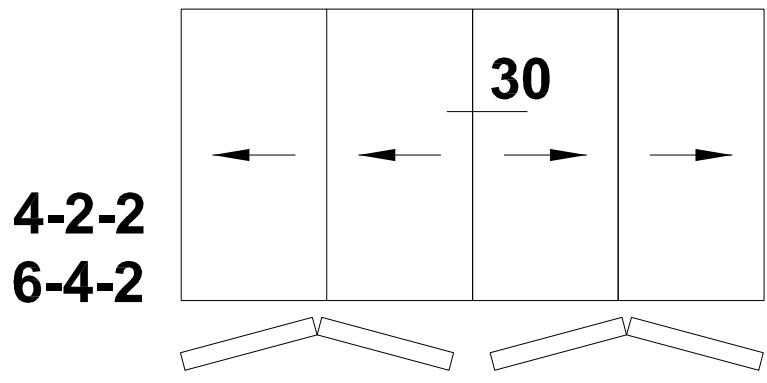
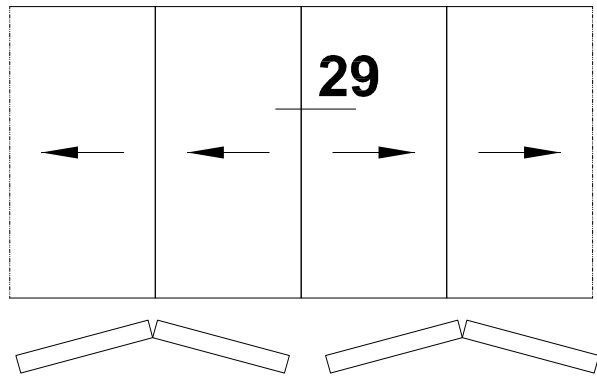
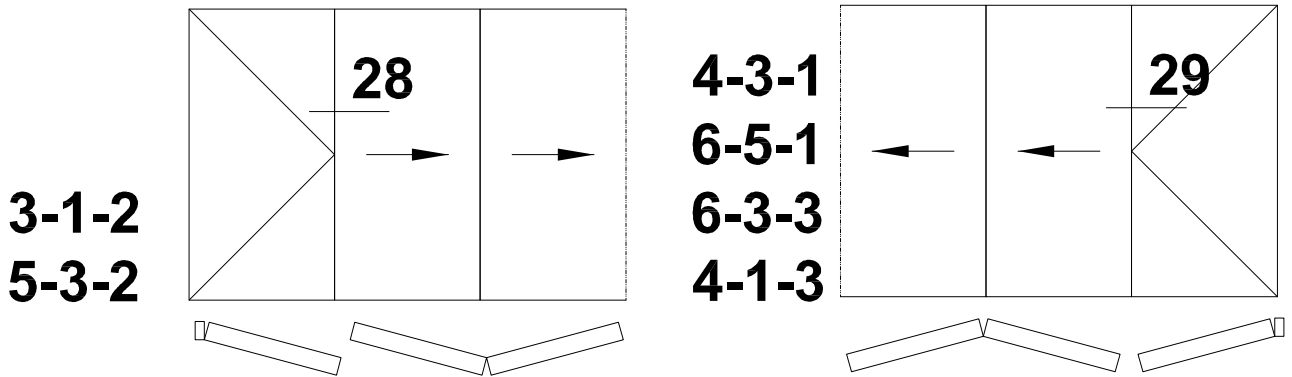

DA-77 FD  
Possible models for inward or outward opening

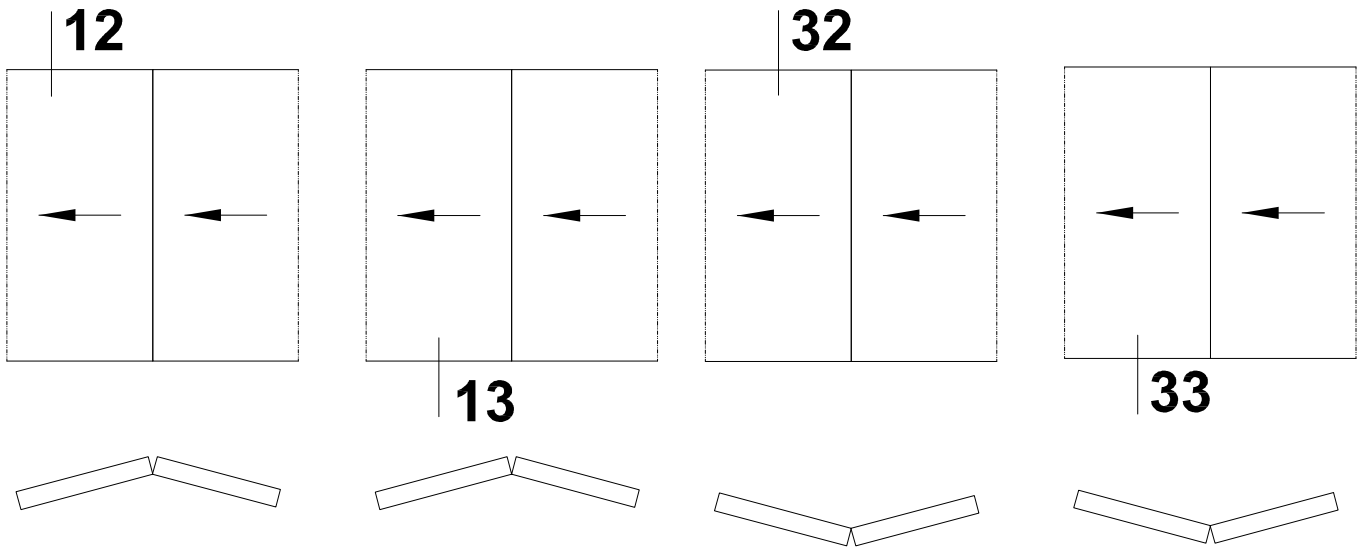

DA-77 FD  
Possible models for inward or outward opening

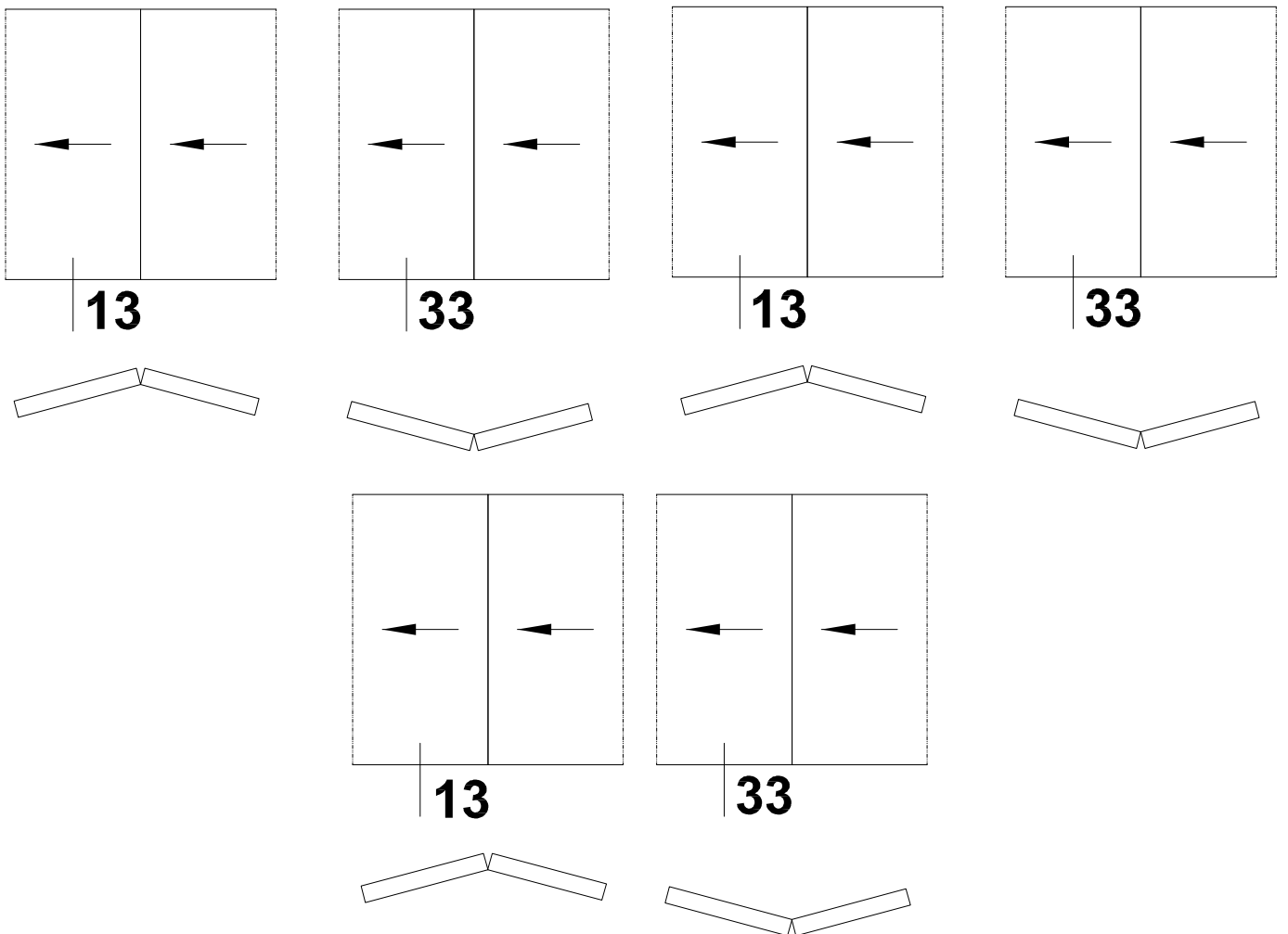



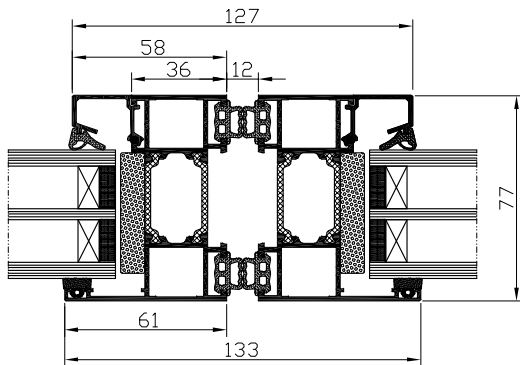

DA-77 FD  
Cross-section: 2, 4, 6, 8, 9, 10, 22,  
24, 26, 28, 29, 30 variant 1

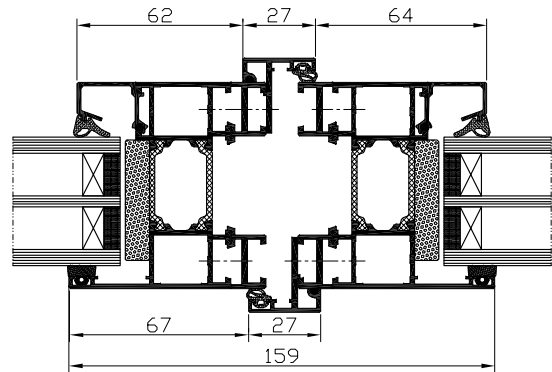

DA-77 FD  
Cross-section: 2, 4, 6, 8, 9, 10, 22,  
24, 26, 28, 29, 30 variant 7

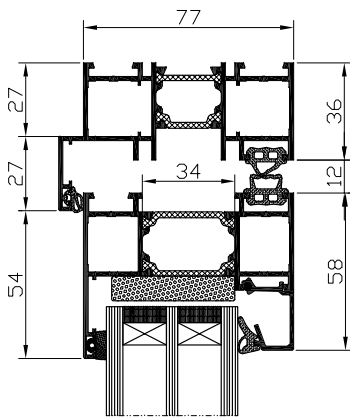

DA-77 FD  
Cross-section: 12, 32 variant 1

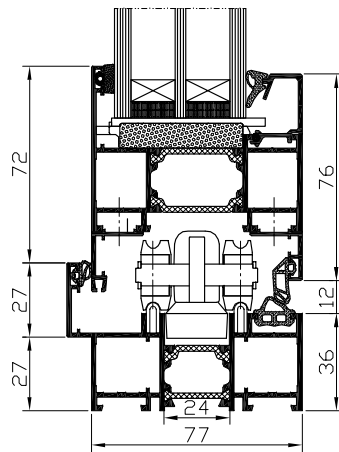

DA-77 FD  
Cross-section: 13, 33 variant 1

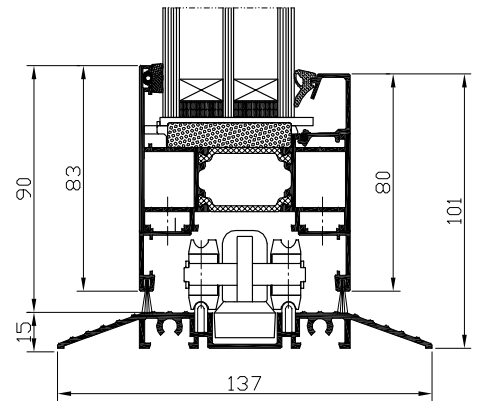

DA-77 FD  
Cross-section: 13, 33 variant 2

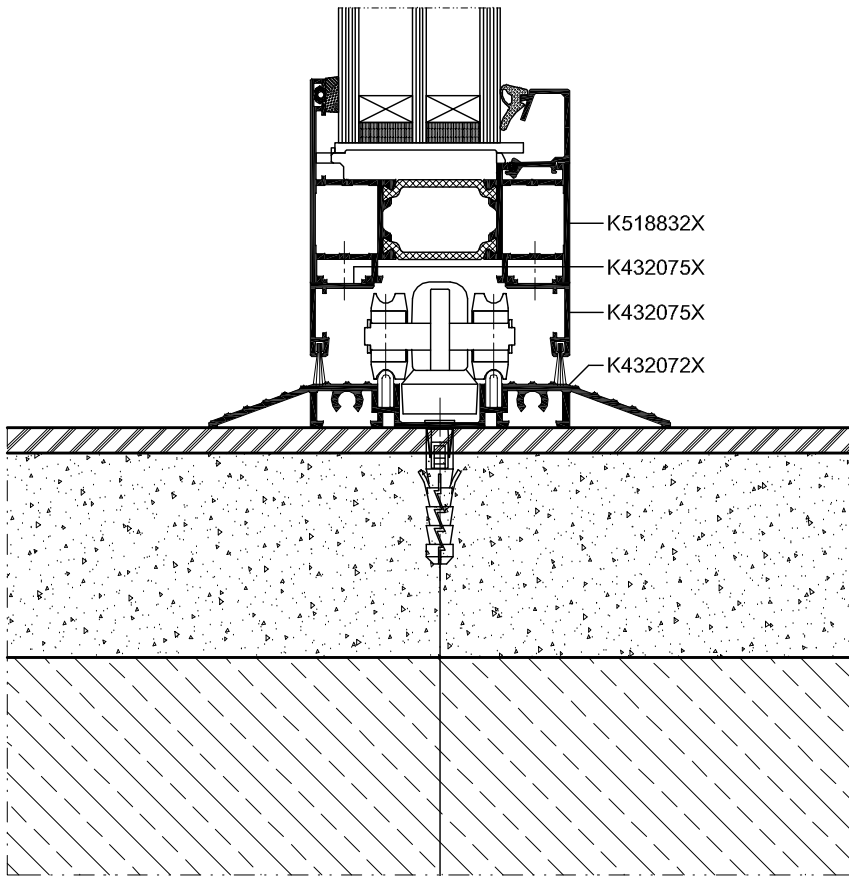

Kolek rozporowy Ø10  
 Expansion bolt Ø10  
 Дюбель Ø10  
 Spreizdübel Ø10

DA-77 FD  
 Assembly

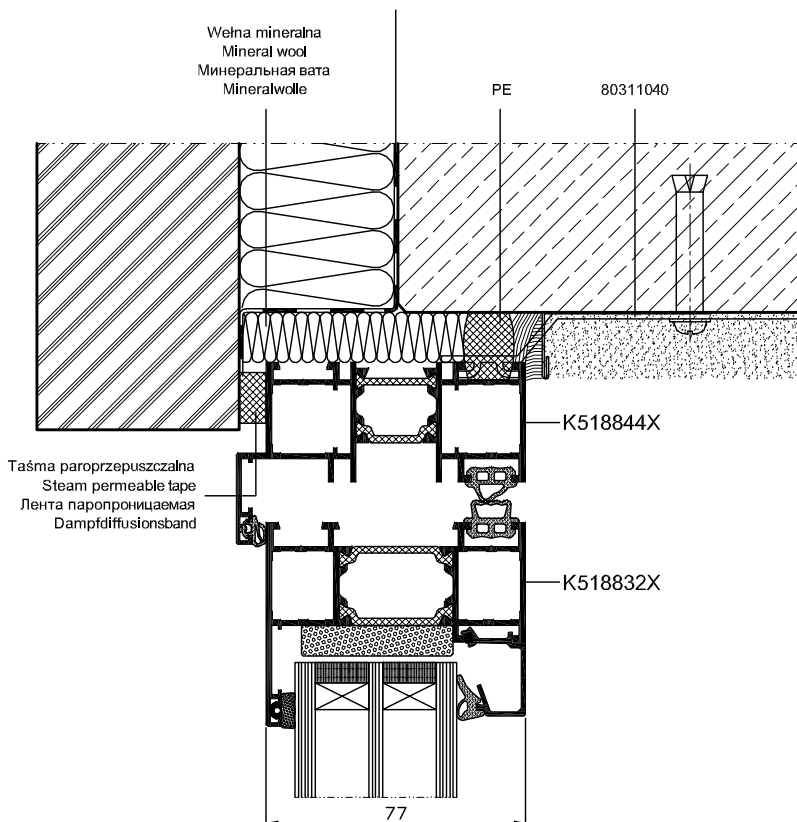

DA-77 FD  
 Assembly



WINDOWS | ROLLER BLINDS | DOORS | GARAGE DOORS  
PVC | TIMBER | ALUMINIUM



Harmony line

Every single day  
around the  
world...

thousands of people test DAKO products in the most demanding testing ground – the laboratory of the real life. DAKO products are used, among others, by people of modern and exotic Japan or living in historical capitals of Europe as well as cold, far north and hot regions of Southern America.

  [www.dako.eu](http://www.dako.eu)



Find out more:

All information about DAKO policy, quality as well as the pictures of DAKO products and informative articles can be found on the website [www.dako.eu](http://www.dako.eu)